

# ISAAC NEWTON

*Life, Labours  
and Legacy*

**Robin Wilson  
&  
Raymond Flood**

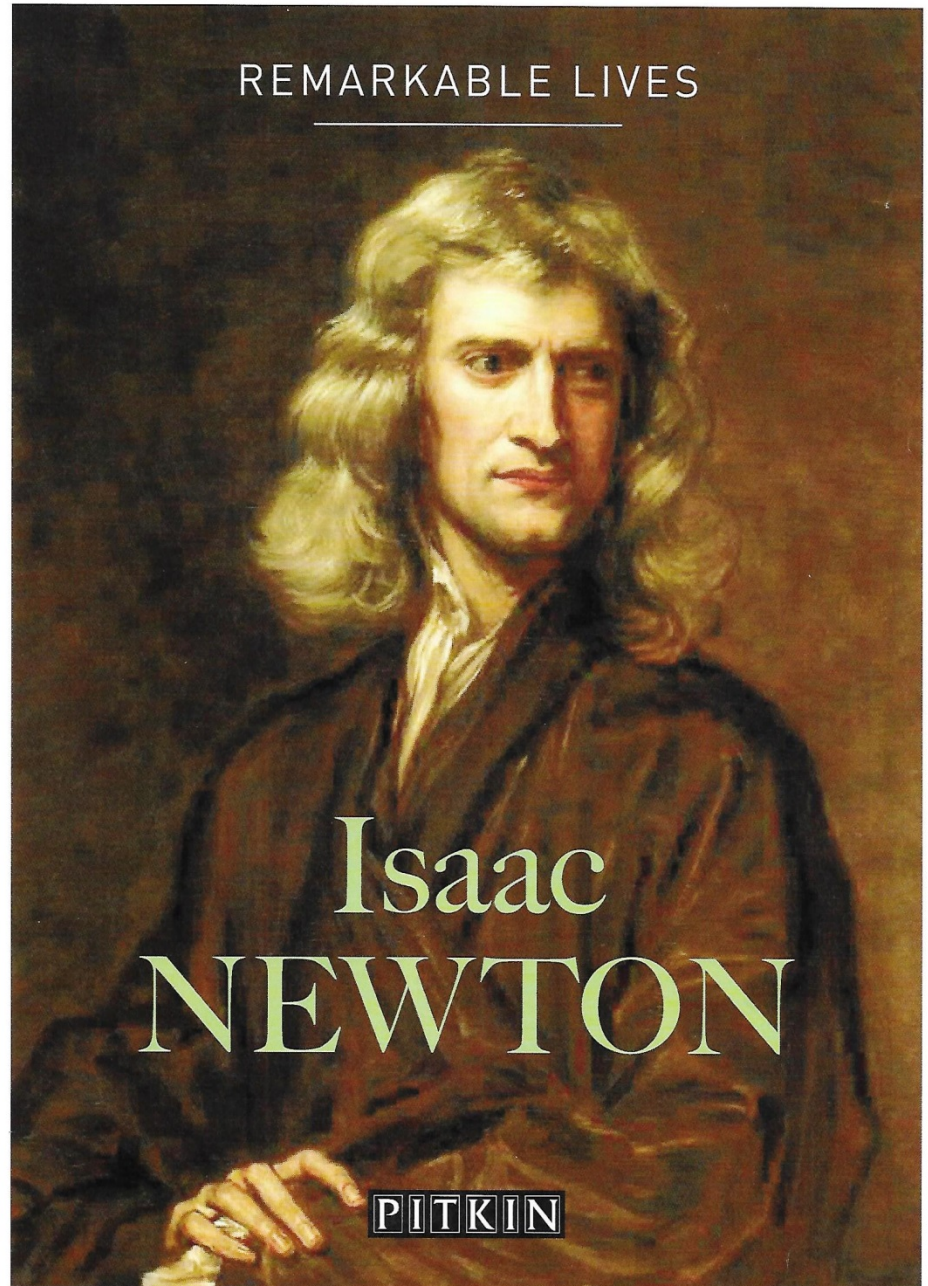

# Contents

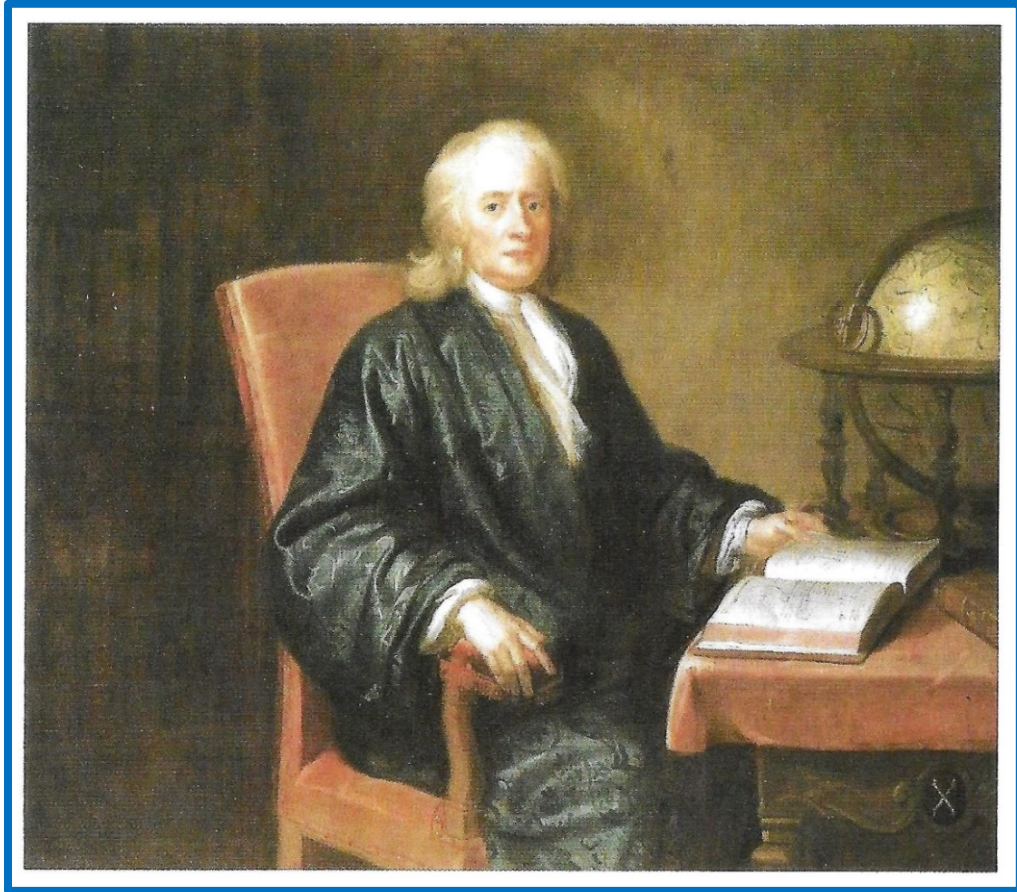

Turbulent times

Early years

Cambridge

Restoration science

Plague & fire

Newton & the apple

Gravity & the *Principia*

Optics

Mathematics

Alchemy

Divinity

London

Final years

Newton's legacy

# Turbulent times (1640-1649)

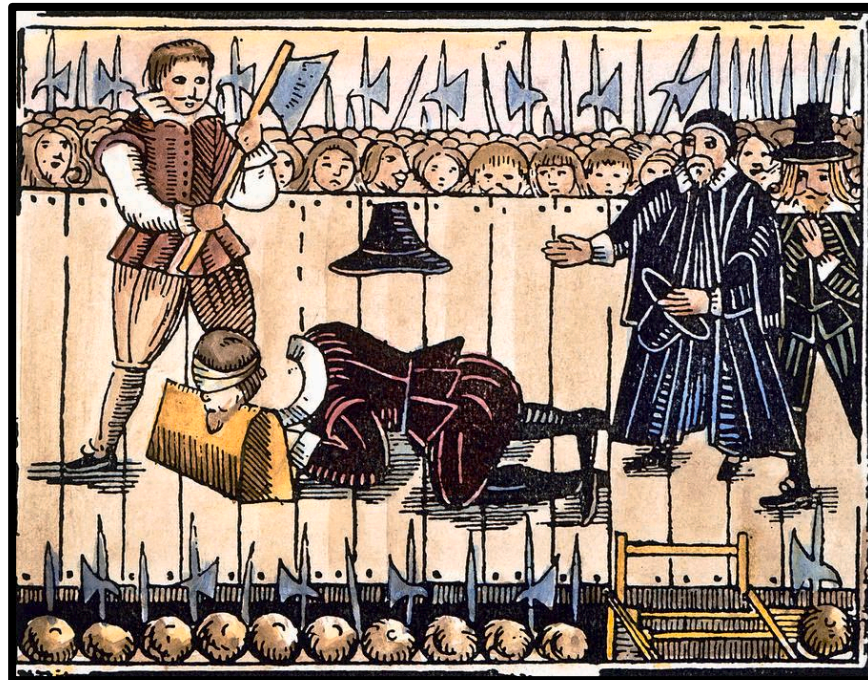

# Turbulent times (1650-1660)





# Woolsthorpe Manor



# Woolsthorpe Manor

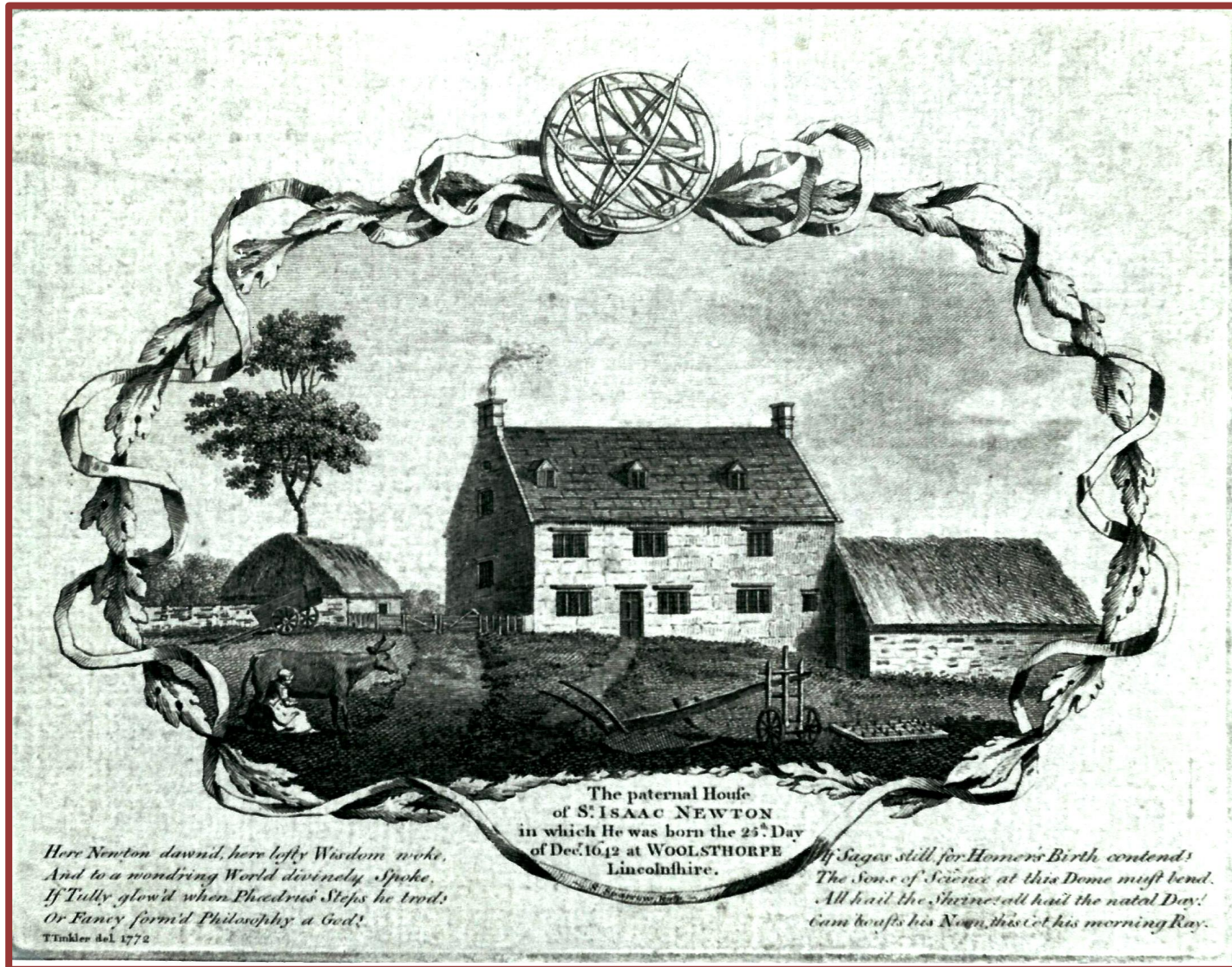

# Grantham

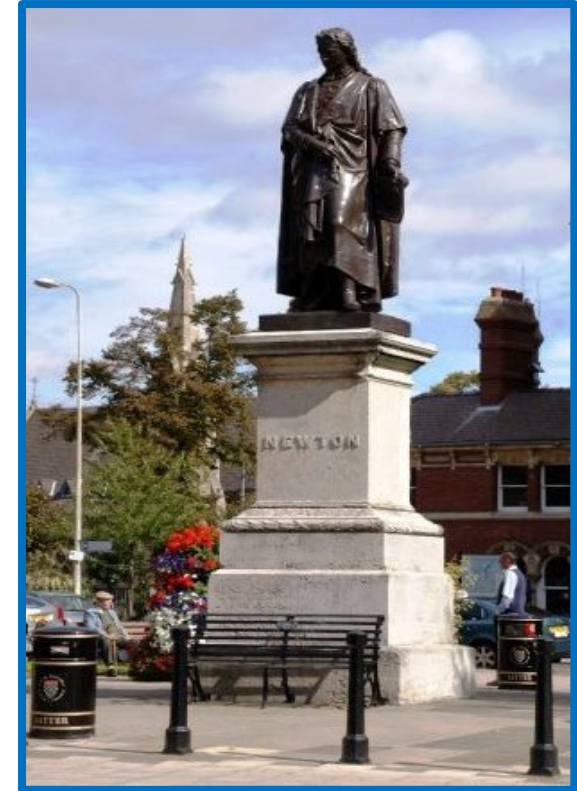
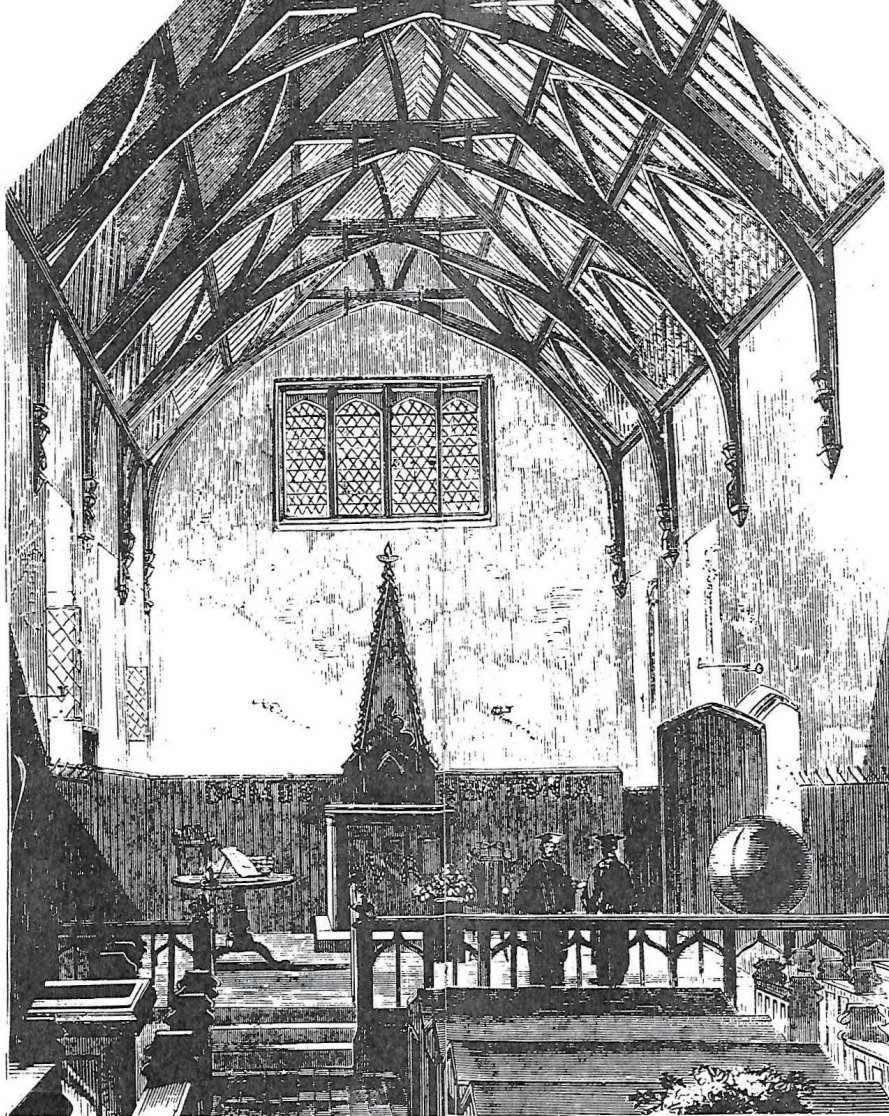
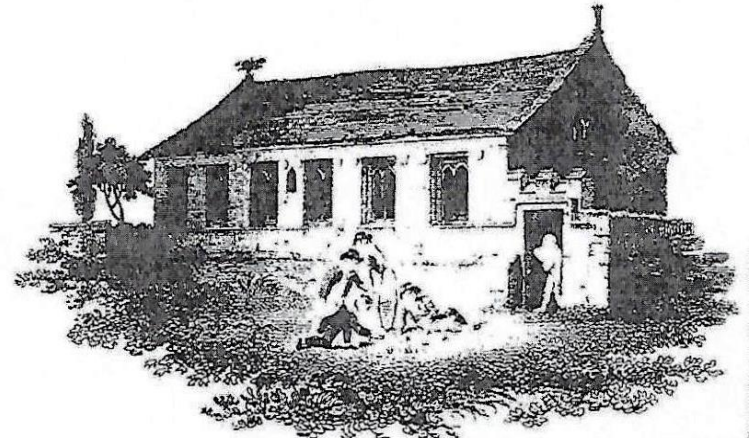

Newton's statue in Grantham

# Back to Woolsthorpe Manor





# An undergraduate at Cambridge



**Roubiliac's statue**



**Trinity College Great Court**

# Cambridge

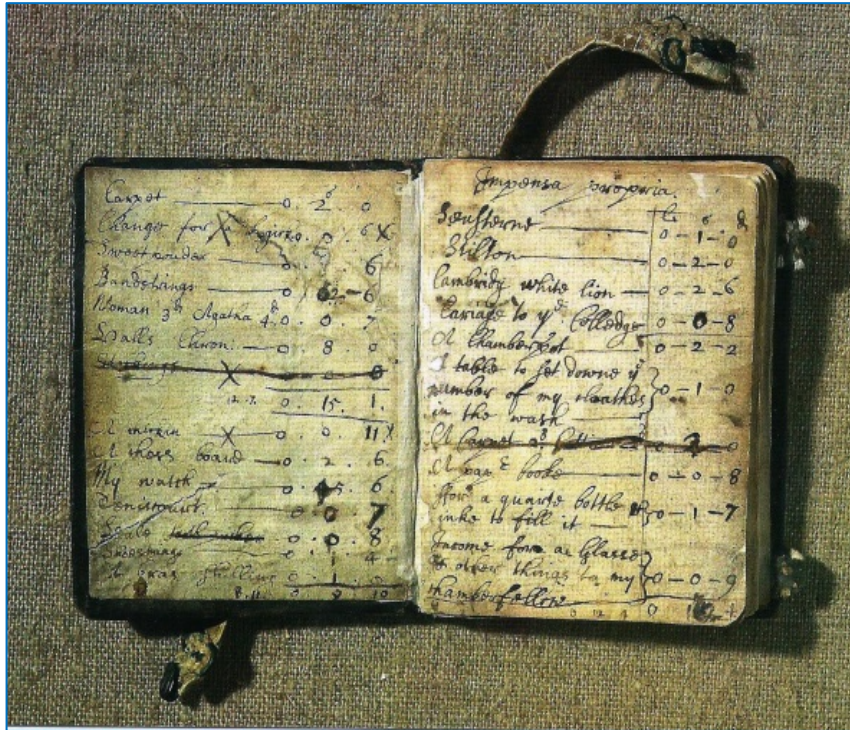

Newton's notebook

Mathematical bridge



# The Royal Society

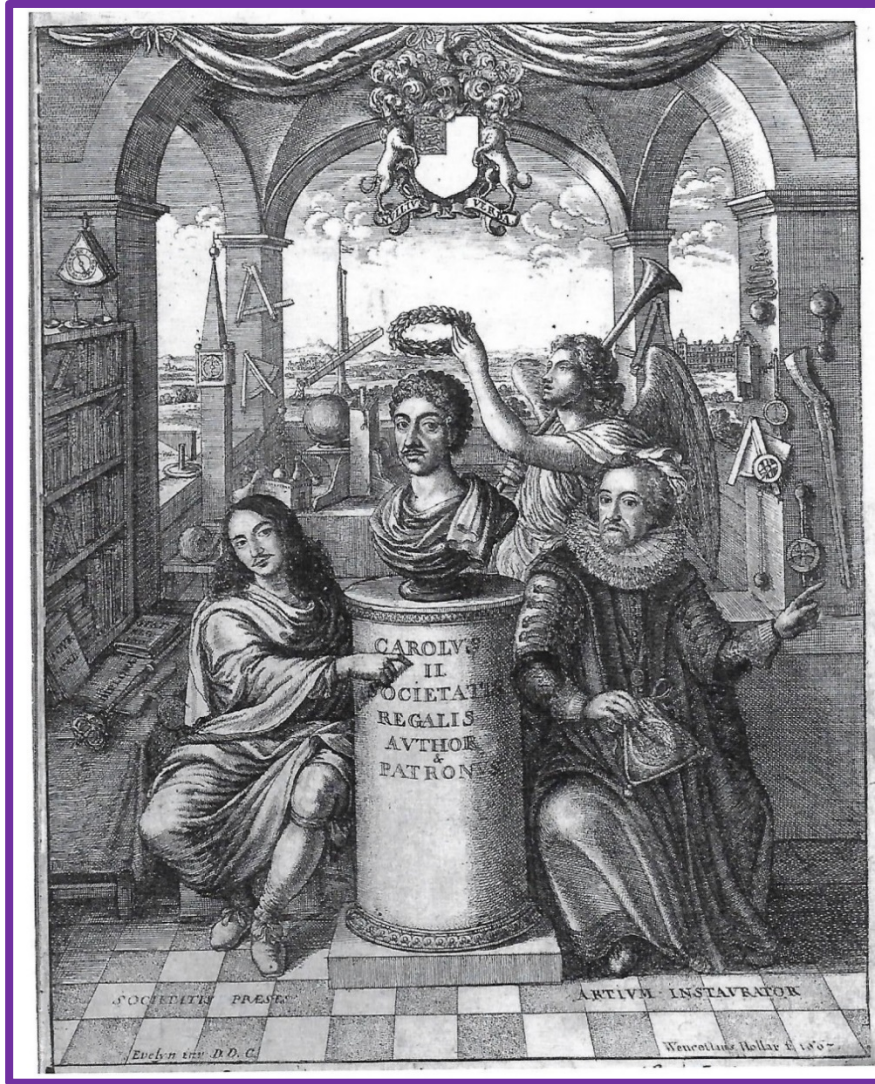

# The Royal Observatory at Greenwich

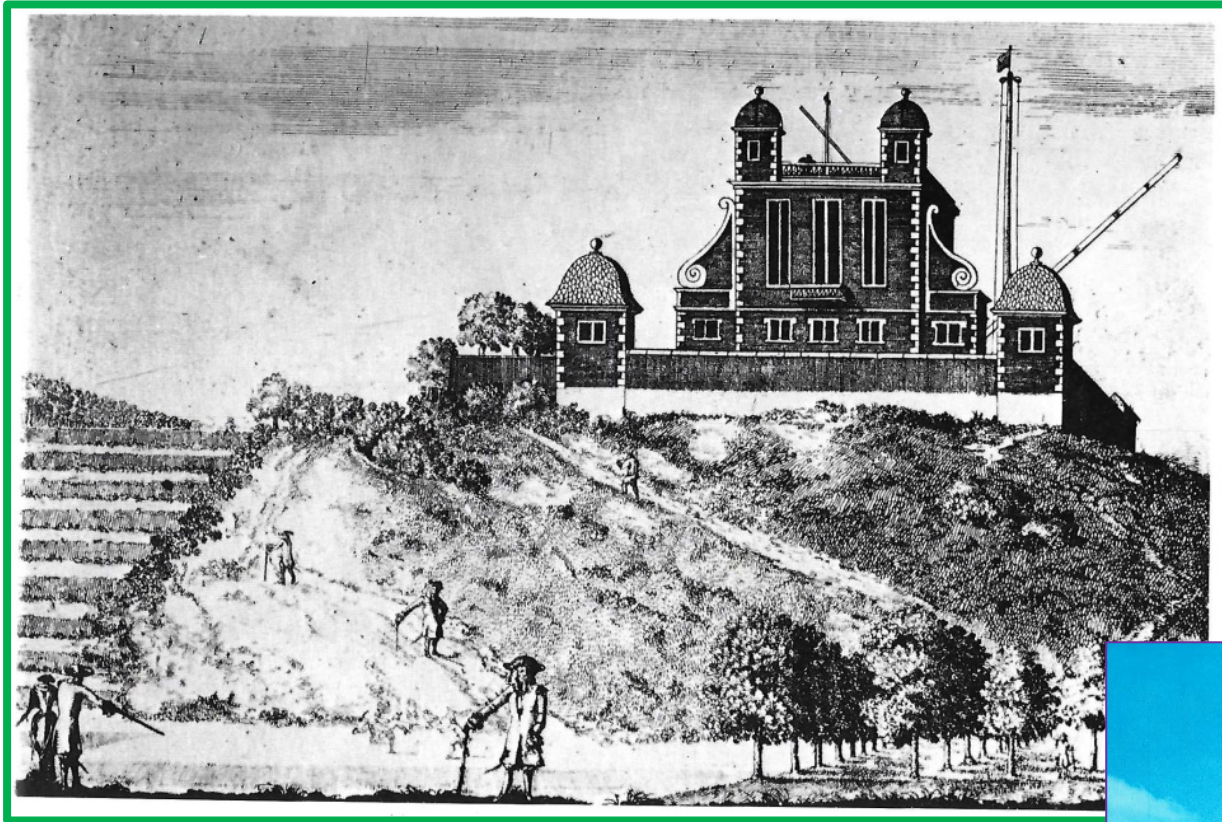

# Boyle & Hooke

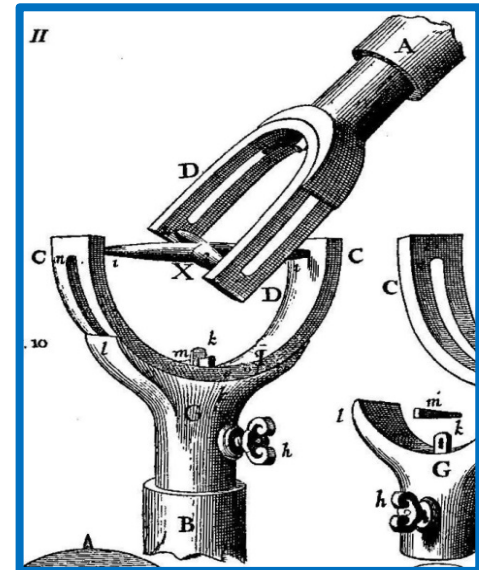
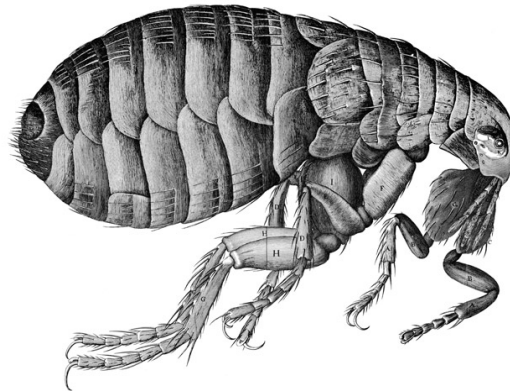
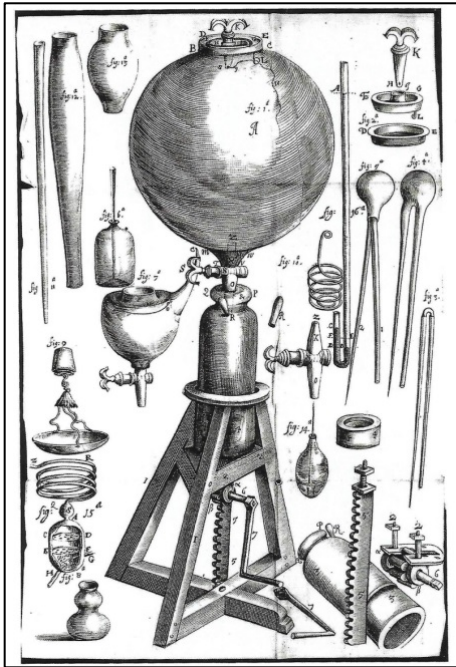
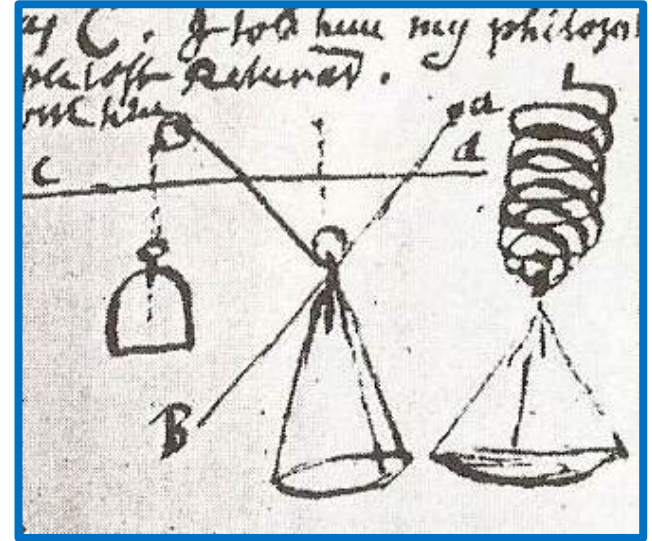

# The Great Plague

*Surely the loude grones of raving sicke men, the struggling panges of soules departing – Servants crying out for maisters: wives for husbands: parents for children, children for their mothers. Here he should have met some frantically running to knock up Sextons: there others fearfully sweating with Coffins to steal dead bodies.*



# Back in Lincolnshire

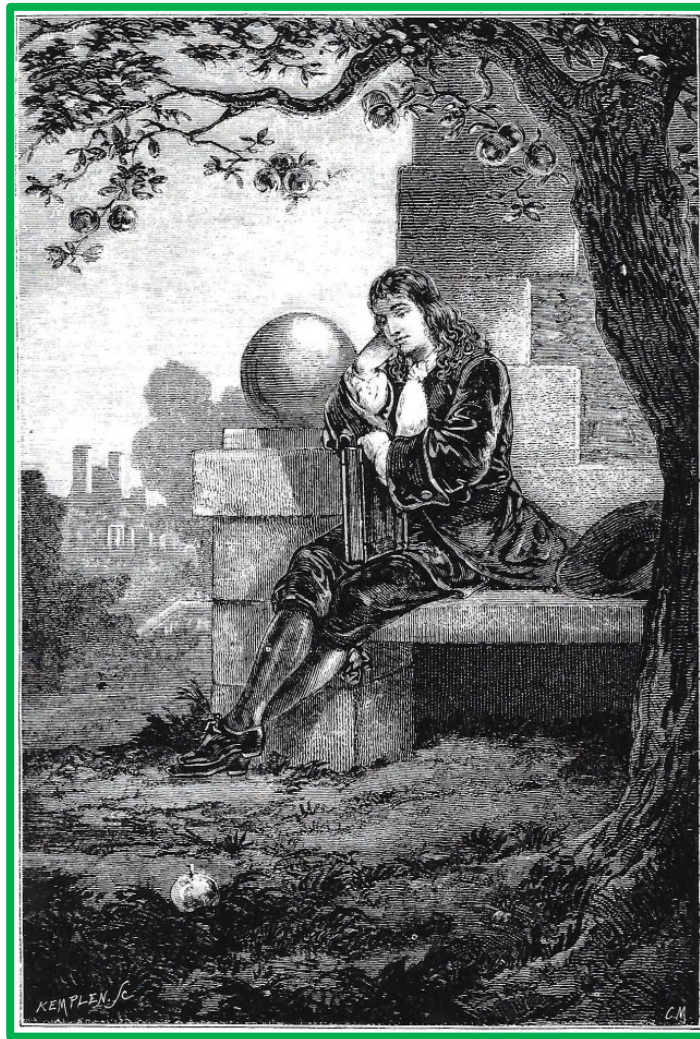

# The Great Fire of London





# The new astronomy

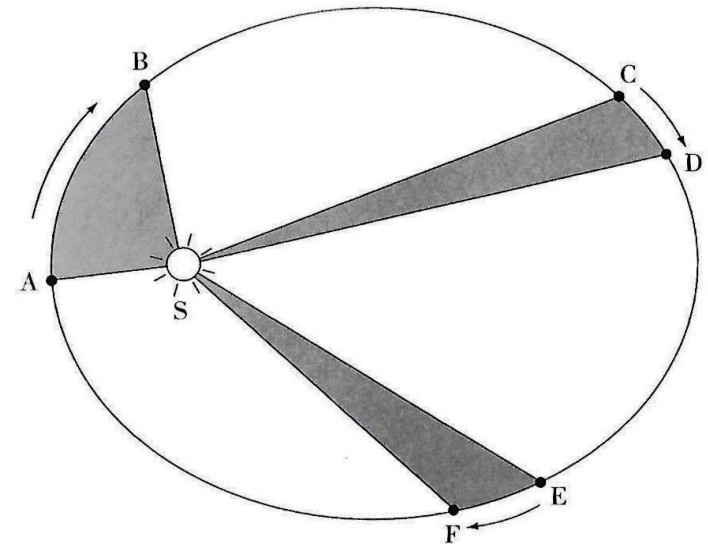
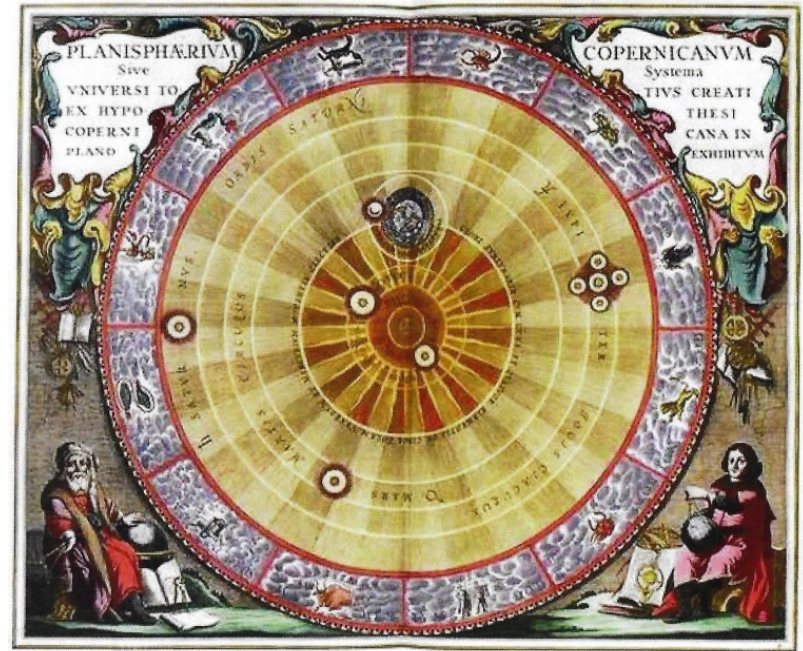
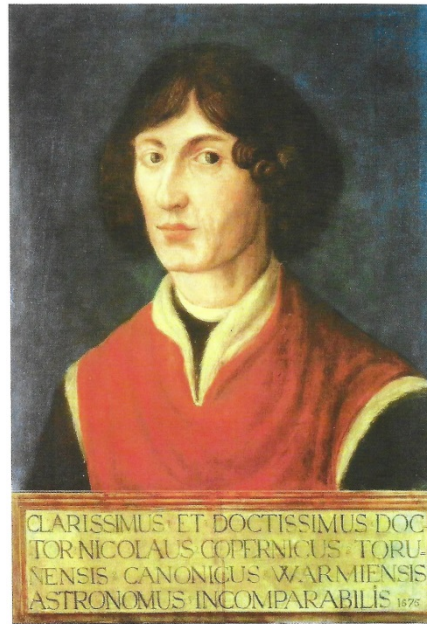



# Newton & the apple



after dinner, the weather being warm, we went into the garden, & drank tea under the shade of some apple-trees; only he, & my self. amidst other discourse, he told me, he was just in the same situation, as when formerly, the notion of gravitation came into his mind. why sh<sup>d</sup>. that apple always descend perpendicularly to the ground, thought he to himself; occasion'd by the fall of an apple, as he sat in a contemplative mood.

**Inverse-square law:** The force of attraction between two objects varies as the product of their masses, and inversely as the square of the distance between them.



# Newton & the apple



The gravity of the situation escapes Isaac Newton

The comic strip consists of nine panels arranged in a 3x3 grid. In the first panel, a man sits on the ground under an apple tree, eating cereal from a box. An apple is shown falling from the tree. In the second panel, the man is still eating, and another apple is falling. In the third panel, the man is eating, and a third apple is falling. In the fourth panel, the man is eating, and a fourth apple is falling. In the fifth panel, the man is eating, and a fifth apple is falling. In the sixth panel, the man is eating, and a sixth apple is falling. In the seventh panel, the man is eating, and a seventh apple is falling. In the eighth panel, the man is eating, and an eighth apple is falling. In the ninth panel, the man is eating, and a ninth apple is falling.

The trouble is they taste too good.



PHILOSOPHIÆ  
NATURALIS  
PRINCIPIA  
MATHEMATICA.

Autore ꝑ S. NEWTON, Trin. Coll. Cantab. Soc. Matheseos  
Professore *Lucasiano*, & Societatis Regalis Sodali.

IMPRIMATUR.  
S. PEPYS, Reg. Soc. PRÆSES.  
*Julii 5. 1686.*

LONDINI,

Jussu Societatis Regiæ ac Typis *Josephi Streater*. Prostat apud  
plures Bibliopolas. Anno MDCLXXXVII.

Newton's  
*Principia*  
*Mathematica*  
(1687)

# Newton's *Principia Mathematica*

[ 50 ]

## SECT. III.

*De motu Corporum in Conicis Sectionibus excentricis.*

Prop. XI. Prob. VI.

*Revolvatur corpus in Elliptici: Requiritur lex vis centripetæ tendentis ad umbilicum Ellipticos.*

Est Ellipse superioris umbilicus S. Agatur SP secans Ellipse tum diametrum DK in E, tum ordinatim applicatam QV in x, & compleatur parallelogrammum QxPR. Patet EP æqualem esse semi-axi majori AC, eo quod acta ab altero Ellipseos umbilico H linea HI ipsi EC parallela, ( ob æquales CS, CH ) æquantur ES, EI, adeo ut EP semisumma sit ipsarum PS, PI, id est ( ob parallelas HI, PR & angulos æquales IP R, HPZ ) ipsorum PS, PH, quæ conjunctim axem totum æ AC adæquant. Ad SP demittatur perpendicularis QT, & Ellipseos latere recto principali ( seu  $\frac{2}{AC} BC^2$  quad. ) dicto L, erit  $LxQR$  ad  $LxPv$  ut  $QR$  ad  $Pv$ ; id est ut PE ( seu AC ) ad PC: &  $LxPv$  ad  $GvP$  ut L ad Gv; &

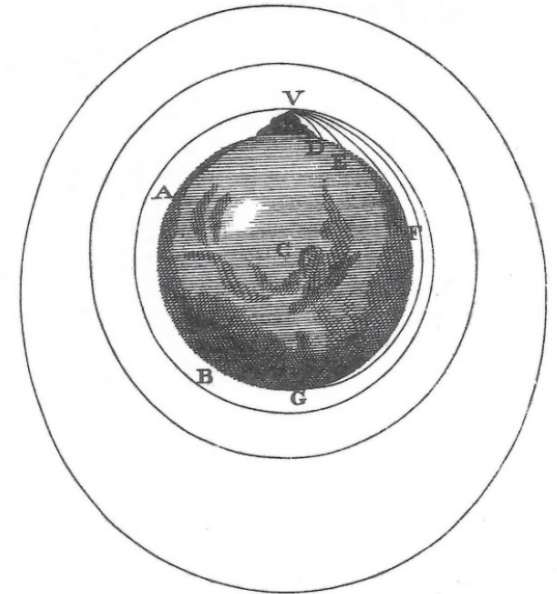
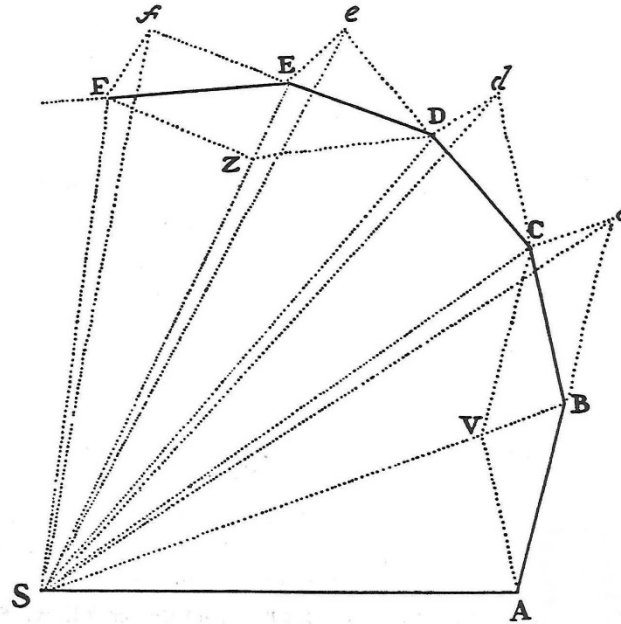
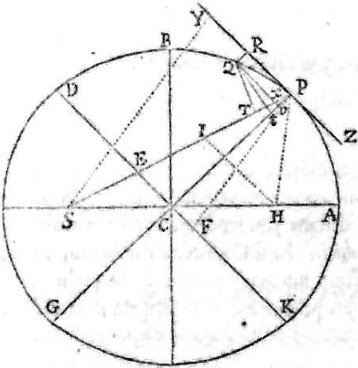

# Newton's laws of motion

1. Every body continues in its state of rest, or of uniform motion in a straight line, unless it is compelled to change that state by forces impressed on it.
2. Any change of motion is proportional to the force, and is made in the direction of the line in which the force is applied.
3. To any action there is an equal and opposite reaction.

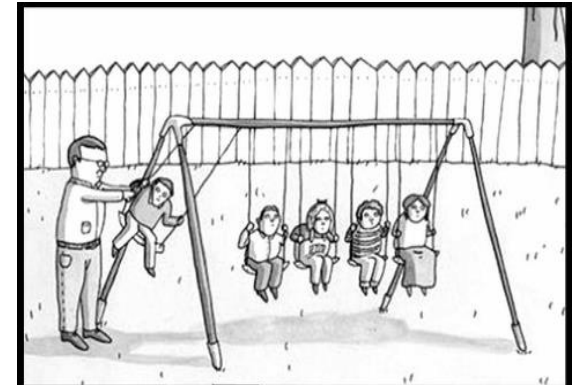
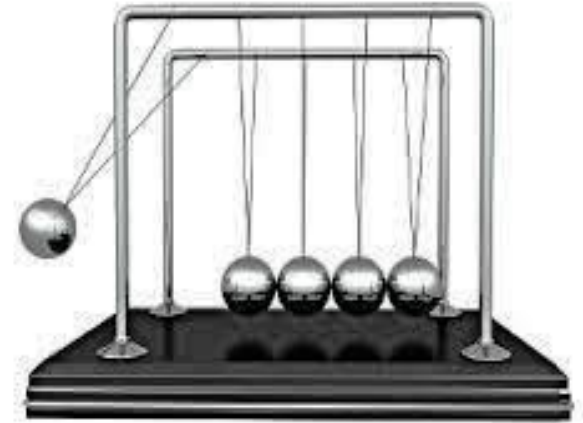

Why science teachers  
should not be given  
playground duty.

EDMUND. HALLEIVS LL.D.  
GEOM. PROF. SAVIL. & R. S. SECRET.

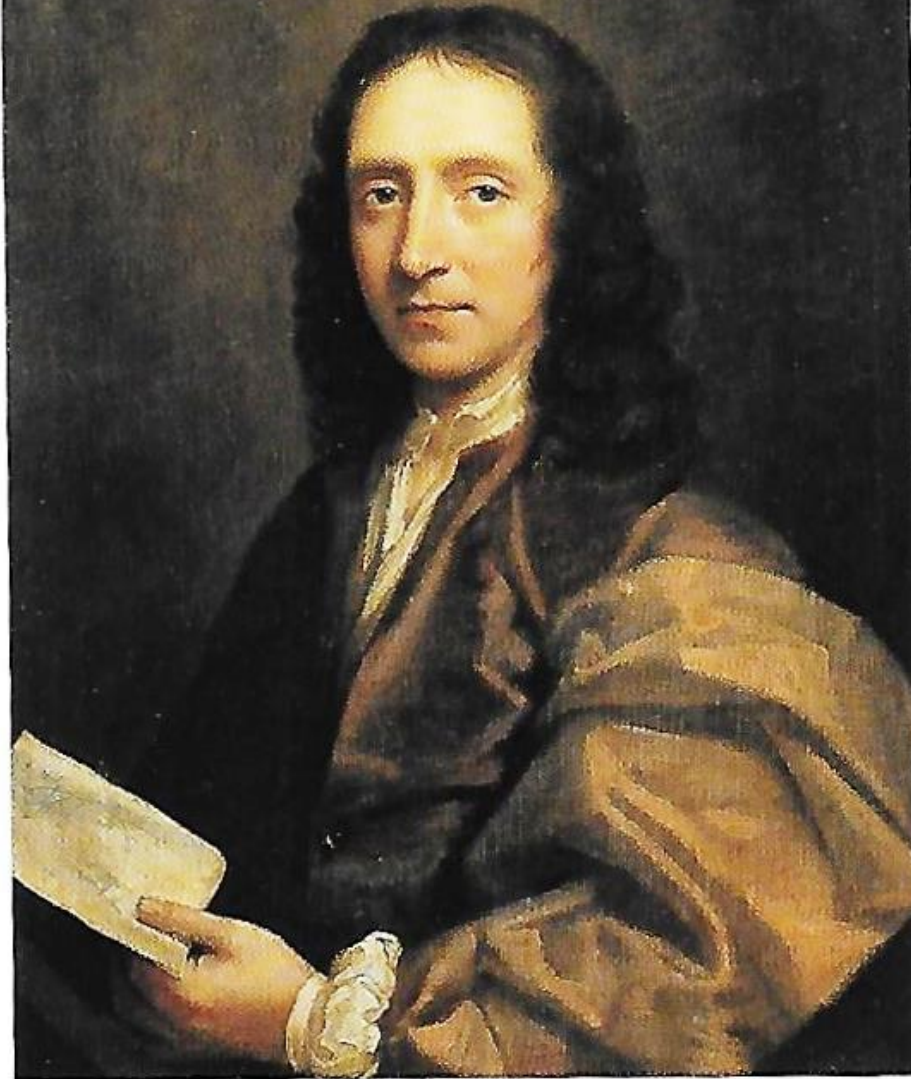

# Edmond Halley

FRANCISCI WILLUGHBEII Armig. *Adam*

DE

## HISTORIA PISCIVM

LIBRI QUATUOR

Jussu & Sumptibus SOCIETATIS REGIÆ  
LONDINENSIS editi.

In quibus non tantum *De Piscibus* in genere agitur, Sed & species omnes, tum ab aliis traditæ, tum novæ & nondum editæ bene multæ, naturæ duçum fervante Methodo dispositæ, accurate describuntur.

Earumque effigies, quotquot haberi potuerunt, vel ad vivum delineatæ, vel ad optima exemplaria impressa; Artifici manu elegantissime in æs incisæ, ad descriptiones illustrandas exhibentur. Cum Appendice Historiæ & Observationes in supplementum Operis collatas complectente.

TOTUM OPUS

Recognovit, Coaptavit, Supplevit,

Librum etiam primum & secundum integros adjecit

JOHANNES RAIUS e Societate REGIÆ.

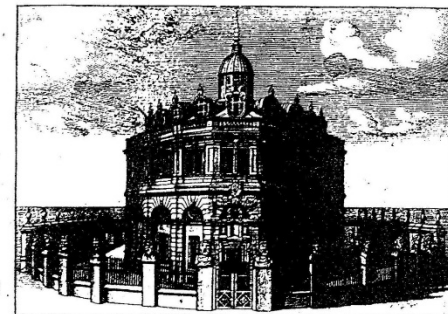

O X O N I I,

E THEATRO SHELDONIANO, Anno Dom. 1686.

# Halley's comet

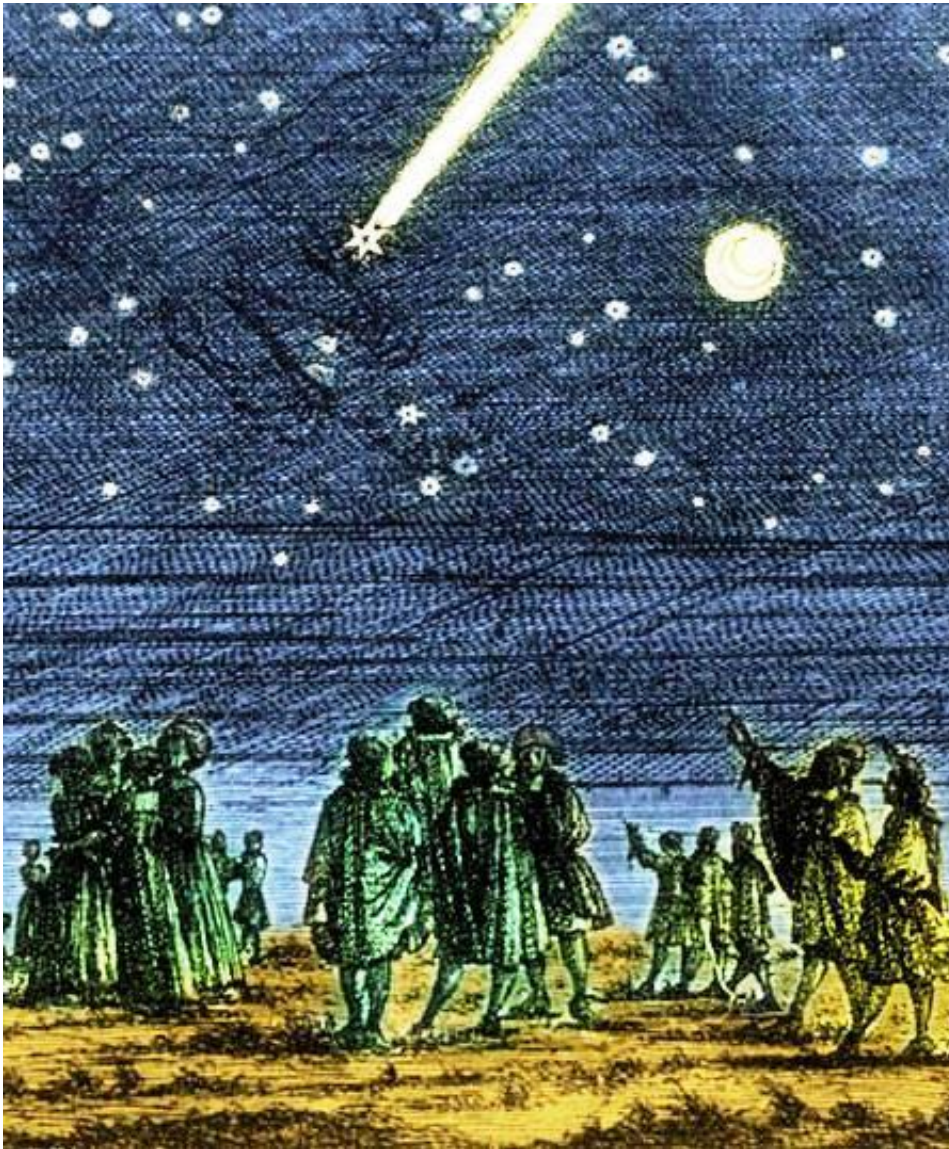

Halley's comet 1682



Halley's comet 1066



# Optics

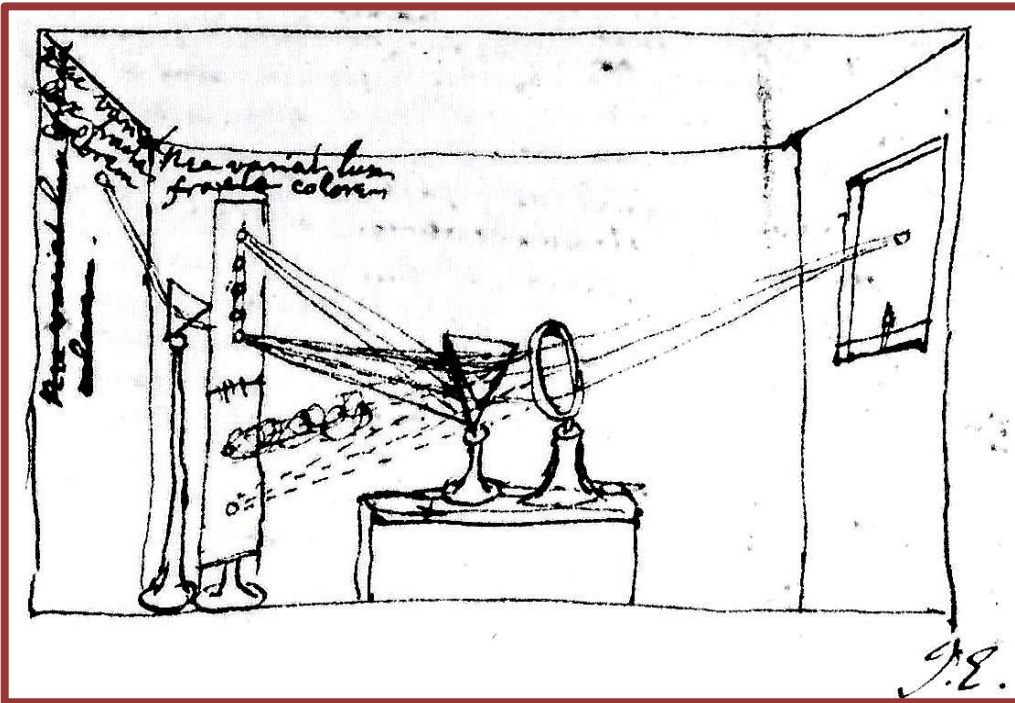
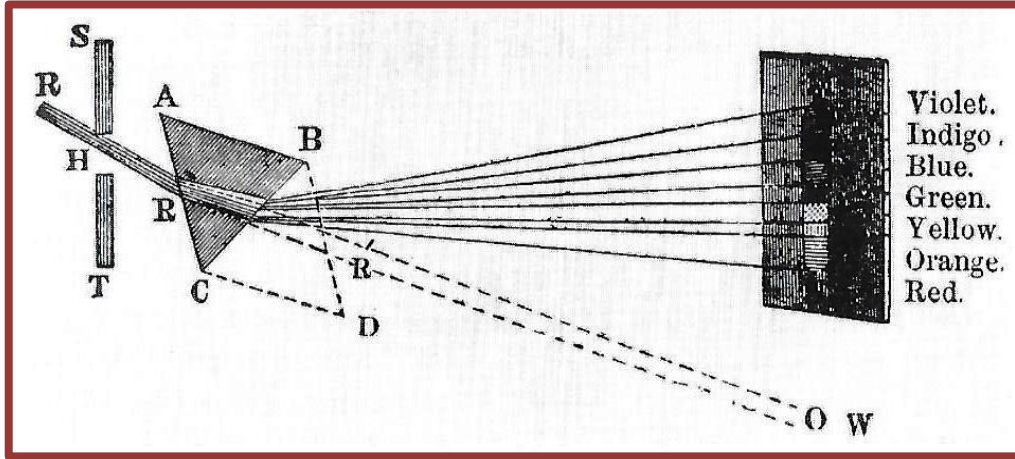

# Optics

more darke & transparent by being soaked in w  
 [for y<sup>e</sup> water fills up y<sup>e</sup> reflecting pores]

58 I took a looking gl  
 & put it betwixt my  
 eye & y<sup>e</sup> bone as  
 neare to y<sup>e</sup> ~~side~~  
 backside of my eye  
 as I could: & pressing  
 my eye wth y<sup>e</sup> end of  
 it (soe as to make y<sup>e</sup>  
 curvatur a, b, c, d, e, f in my  
 eye) there appeared severall  
 white darke & coloured circles

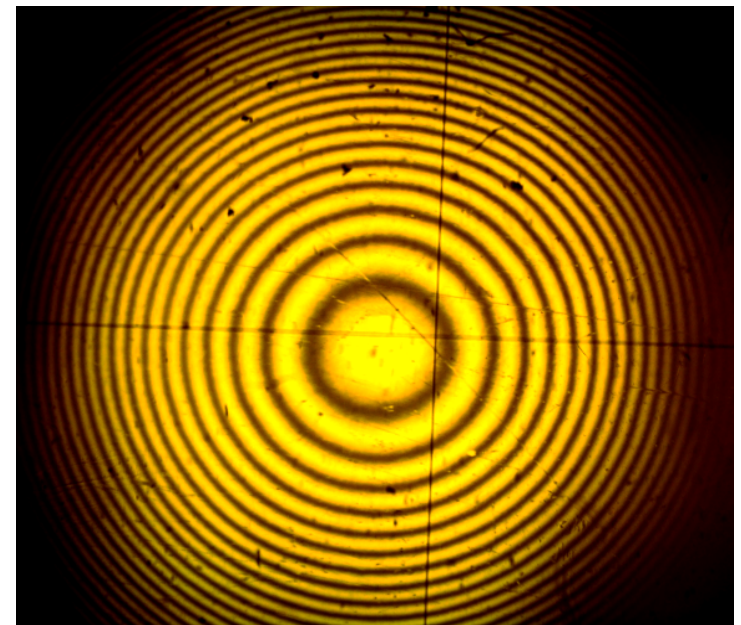
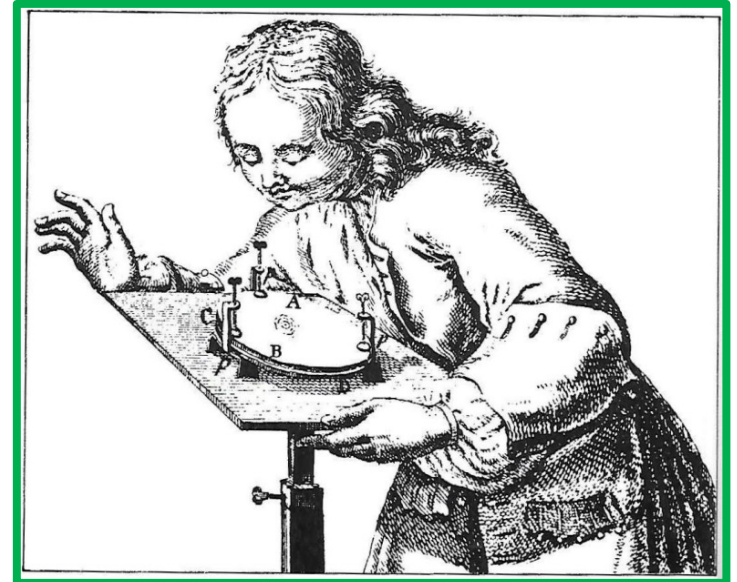

# Newton & music

rational.			
12.	12,000000.	12.	$\frac{1}{1}$ 360 360,000000 G
11.	10,882687.	$11-\frac{1}{11}$	$\frac{11}{10}$ 384 381,406678 *
10.	9,966900.	$10-\frac{1}{11}$	$\frac{10}{9}$ 405 404,086406 F
9.	8,847487.	$9-\frac{1}{11}$	$\frac{9}{8}$ 432 428,114481 E
8.	8,135863.	$8+\frac{1}{17}$	$\frac{8}{7}$ 450 453,571578 *
7.	7,099550.	$7+\frac{1}{17}$	$\frac{7}{6}$ 480 480,542367 D
6.	5,902237.	$6-\frac{1}{11}$	$\frac{12}{5}$ 512 509,116882 *
5.	4,980450.	$5-\frac{1}{11}$	$\frac{12}{5}$ 540 539,390539 *
4.	3,863137.	$4-\frac{1}{15}$	$\frac{4}{3}$ 576 577,464474 B
3.	3,156413.	$3+\frac{1}{13}$	$\frac{5}{4}$ 600 605,445467 *
2.	2,099100.	$2+\frac{1}{11}$	$\frac{8}{7}$ 640 641,446973 A
1.	1,117313.	$1+\frac{1}{11}$	$\frac{16}{9}$ 675 679,5895149 *
0.	0,000000.	0.	1 720 720,000000 G

*Handwritten notes at bottom of table:*  
 Musical half notes  
 Musical + notes  
 C string  
 D string  
 E string  
 F string  
 G string  
 A string  
 B string  
 C string  
 D string

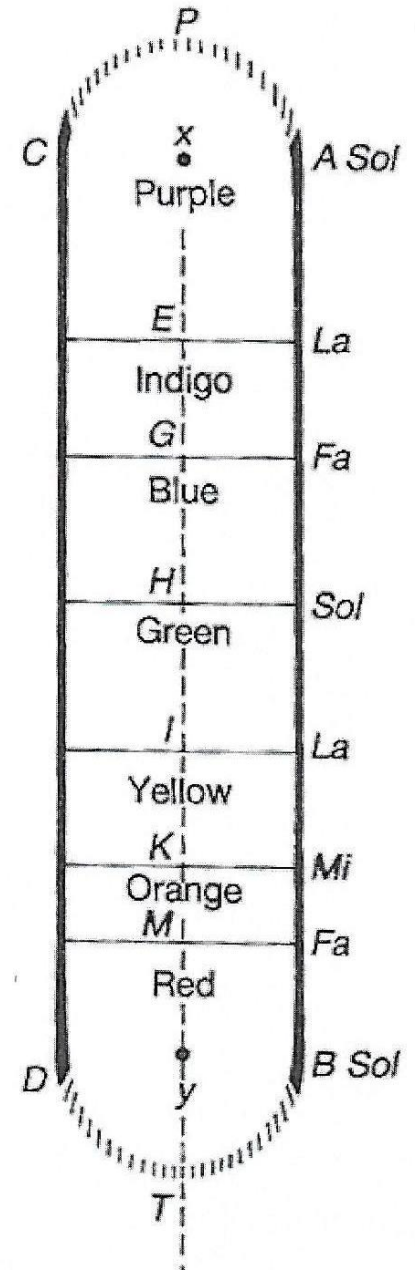
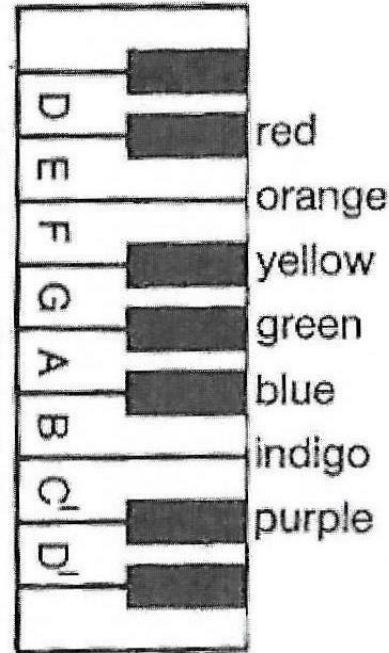

# Mathematics: Calculus

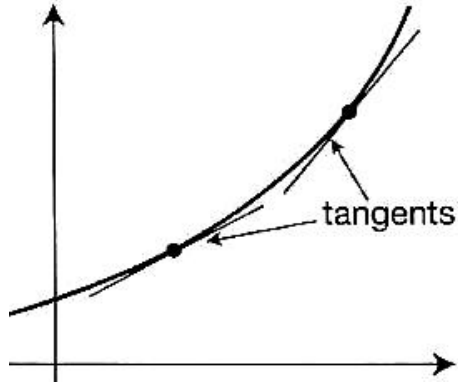

differentiation

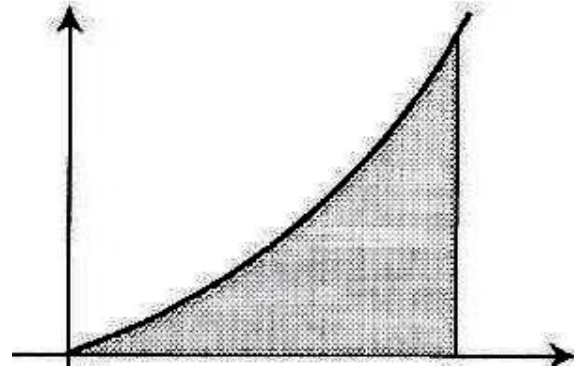

integration

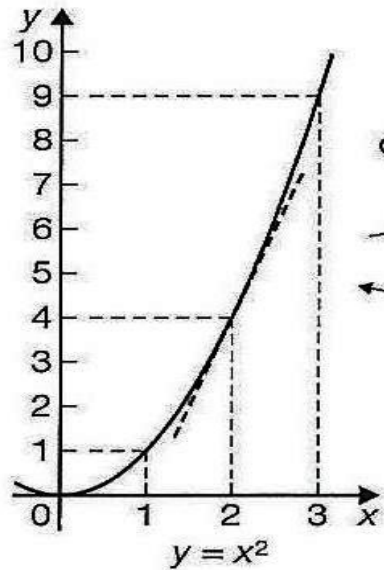

differentiate to find tangents

integrate to find areas

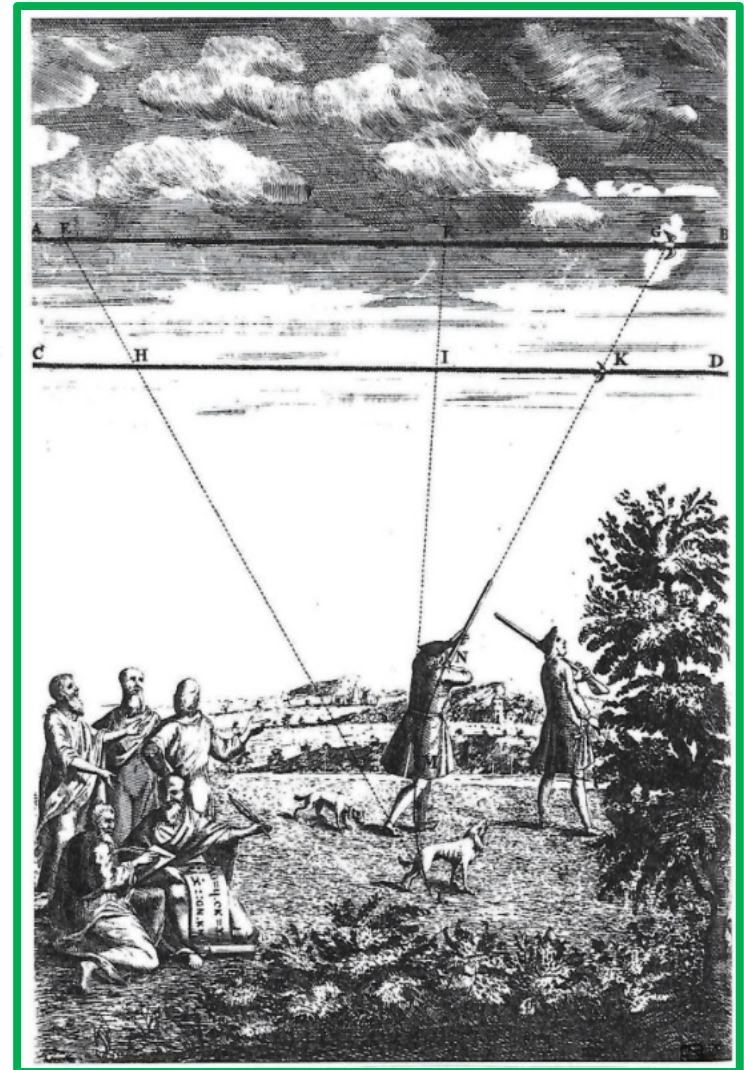
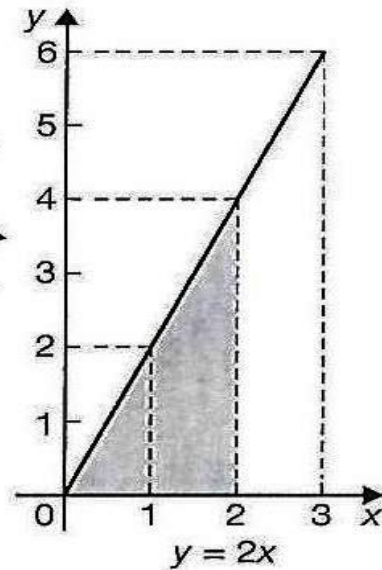

# Mathematics: Curves

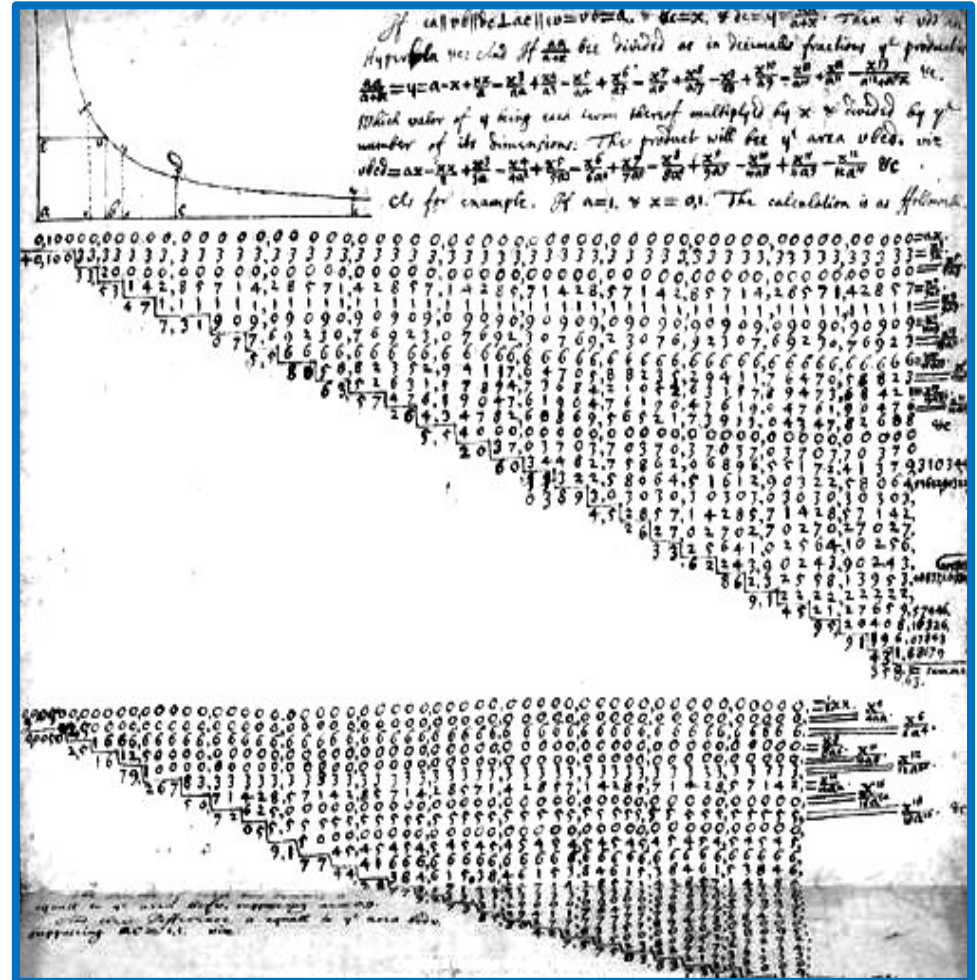
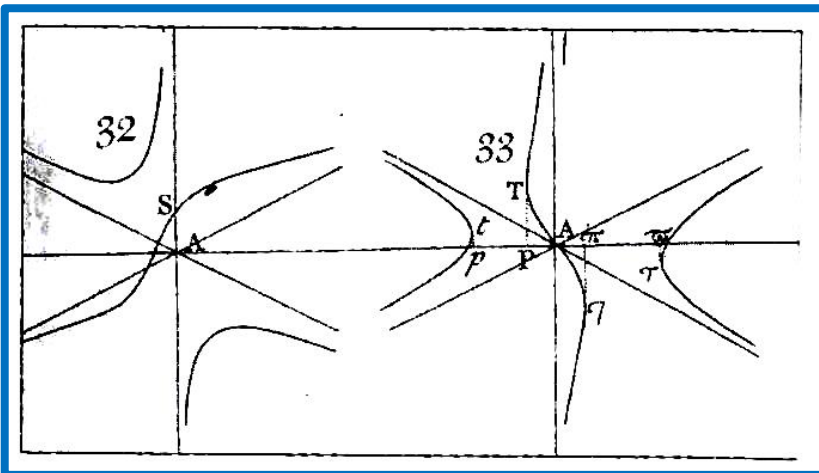
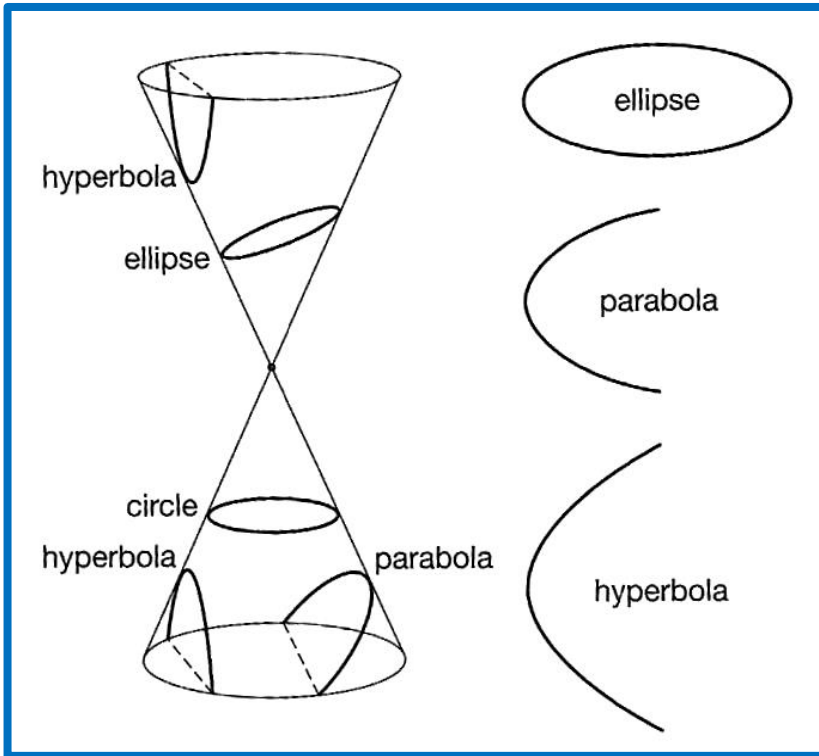

# Alchemy

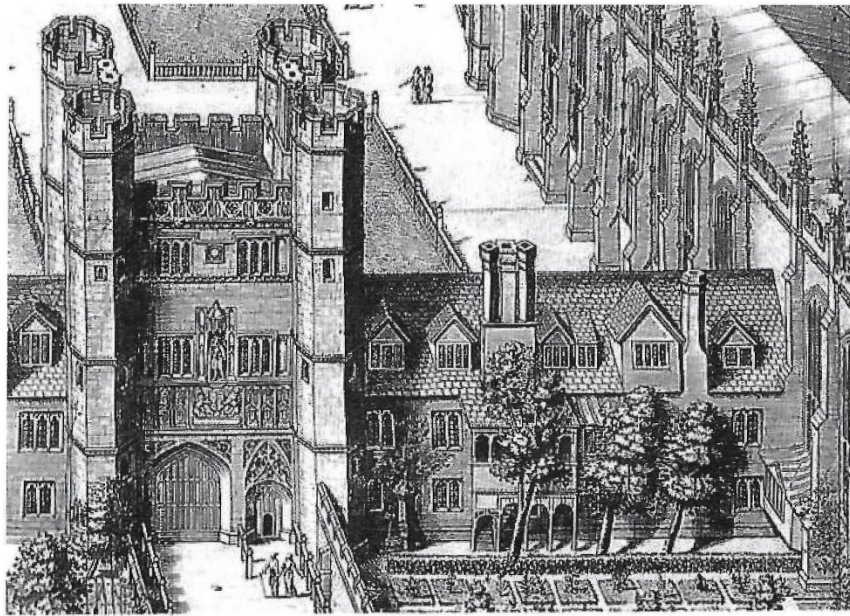

Gold,  $\odot$ ,  $\text{♁}$ ,  $\text{♁}^+$ ,  $\text{♁}^+$   
 Silver  $\text{☾}$ ,  $\text{☾}$ ,  $\text{☾}$ ,  $\text{☾}$ ,  $\text{☾}$   
 Copper  $\text{♀}$ ,  $\text{♁}$ ,  
 Iron  $\text{♂}$   
 Tin  $\text{♃}$ ,  $\text{♃}$   
 Lead  $\text{♄}$ ,  $\text{♄}$ ,  $\text{♄}$ ,  $\text{♄}$   
 Mercury  $\text{☿}$ ,  $\text{☿}$ ,  $\text{☿}$ ,  $\text{☿}$ ,  $\text{☿}$ ,  $\text{☿}$ ,  $\text{☿}$ ,  $\text{☿}$   
 Antimony  $\text{♁}$   
 Sulphur  $\text{♁}$ ,  $\text{♁}$   
 Sublimat  $\text{♁}$ ,  $\text{♁}$ ,  $\text{♁}$   
 Vitriol  $\text{♁}$ ,  $\text{♁}$   
 Salt  $\text{♁}$ ,  $\text{♁}$   
 Niter  $\text{♁}$ ,  $\text{♁}$ ,  $\text{♁}$ ,  $\text{♁}$ ,  $\text{♁}$   
 Tartar  $\text{♁}$ ,  $\text{♁}$ ,  $\text{♁}$ ,  $\text{♁}$ ,  $\text{♁}$ ,  $\text{♁}$   
 Sal armoniac  $\text{♁}$ ,  $\text{♁}$ ,  $\text{♁}$ ,  $\text{♁}$ ,  $\text{♁}$   
 Ubiab, Almasadant

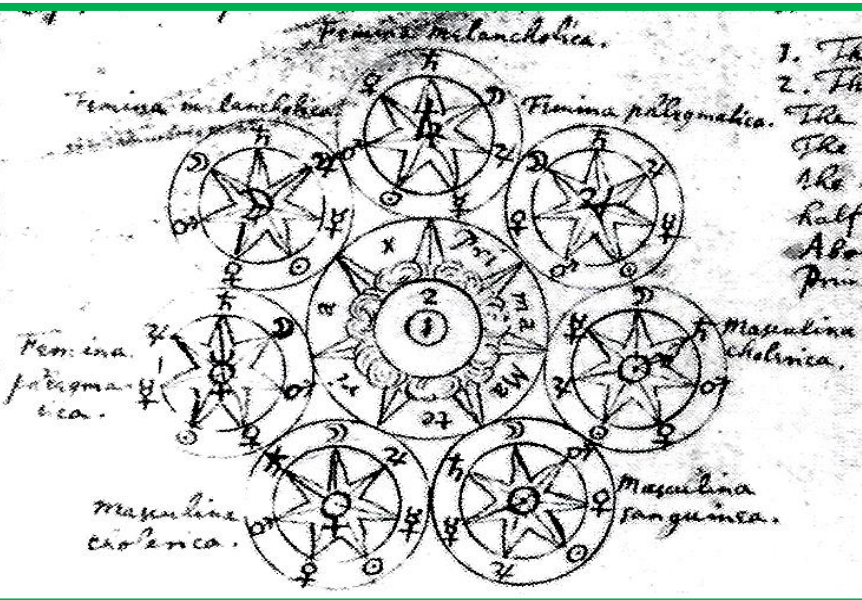

# Divinity

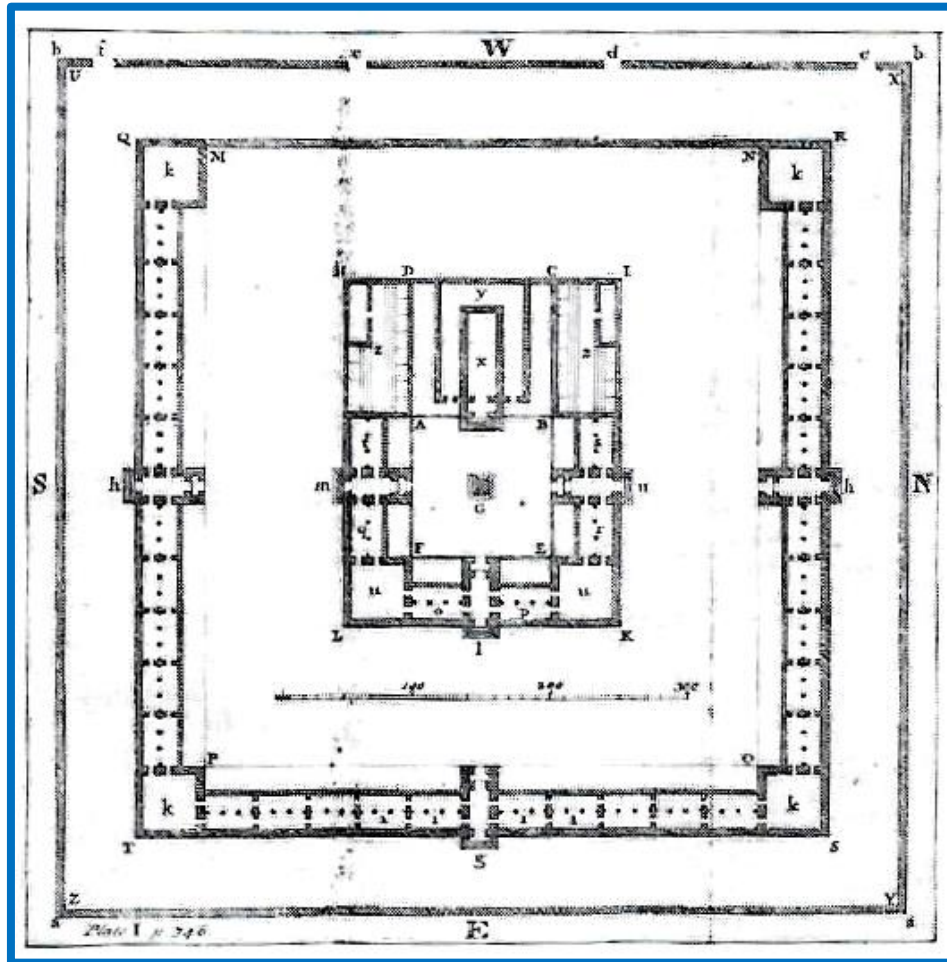

OBSERVATIONS  
UPON THE  
PROPHECIES  
OF  
*DANIEL,*  
AND THE  
APOCALYPSE  
OF  
*St. JOHN.*

---

In Two PARTS.

---

By Sir *ISAAC NEWTON.*

---

*DUBLIN:*

Printed by S. POWELL,

For GEORGE RISK, at the *Shakespeare's-Head*,  
GEORGE EWING, at the *Angel and Bible*, and  
WILLIAM SMITH, at the *Hercules*, in *Dame's-  
street*, Bookellers, M. DCC. XXXIII.

# London: The Royal Mint

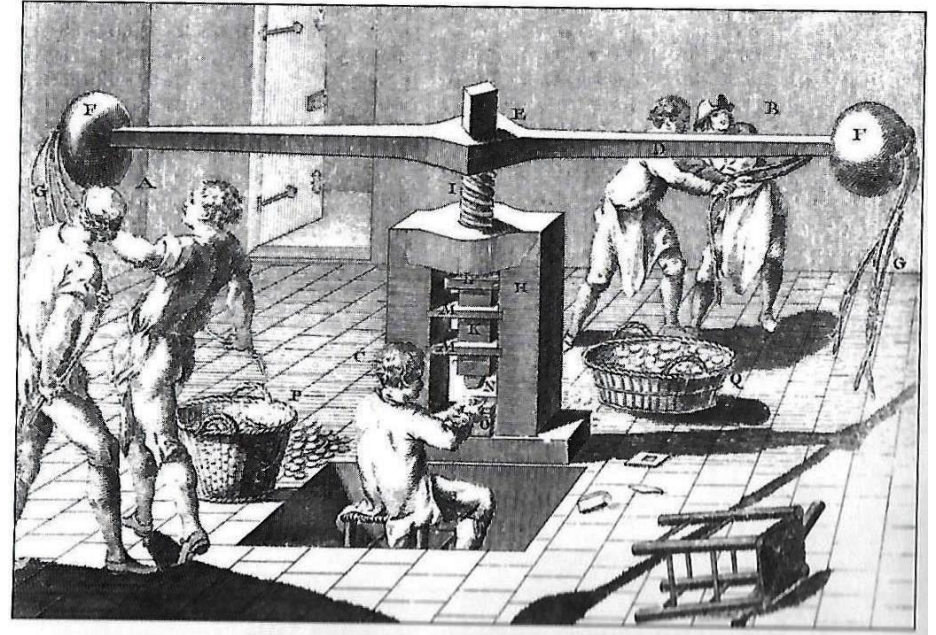



# London: The Royal Society

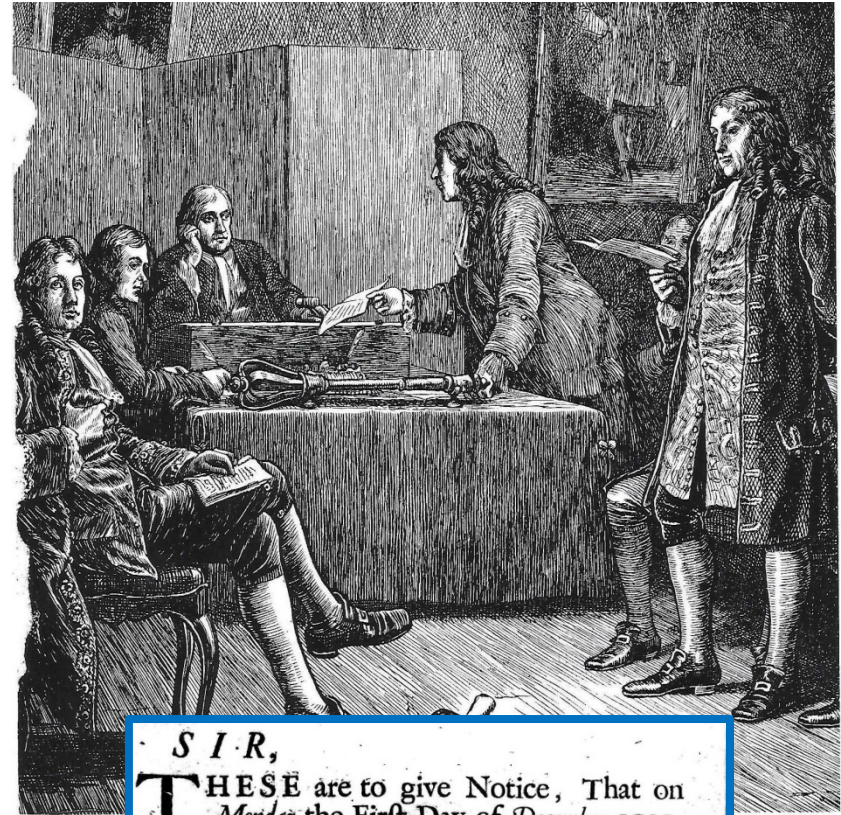

S I R,  
THESE are to give Notice, That on  
Monday the First Day of December 1712,  
(being the next after St. ANDREW'S  
DAY) the Council and Officers of the ROYAL  
SOCIETY are to be Elected for the  
Year ensuing; at which ELECTION  
your Prefence is expected, at Nine of the  
Clock in the Forenoon, at the House of  
the ROYAL SOCIETY, in Crane Court,  
Fleet Street.

To  
Thomas Street Elg  
J. Newton P.R.S.

# Achievements

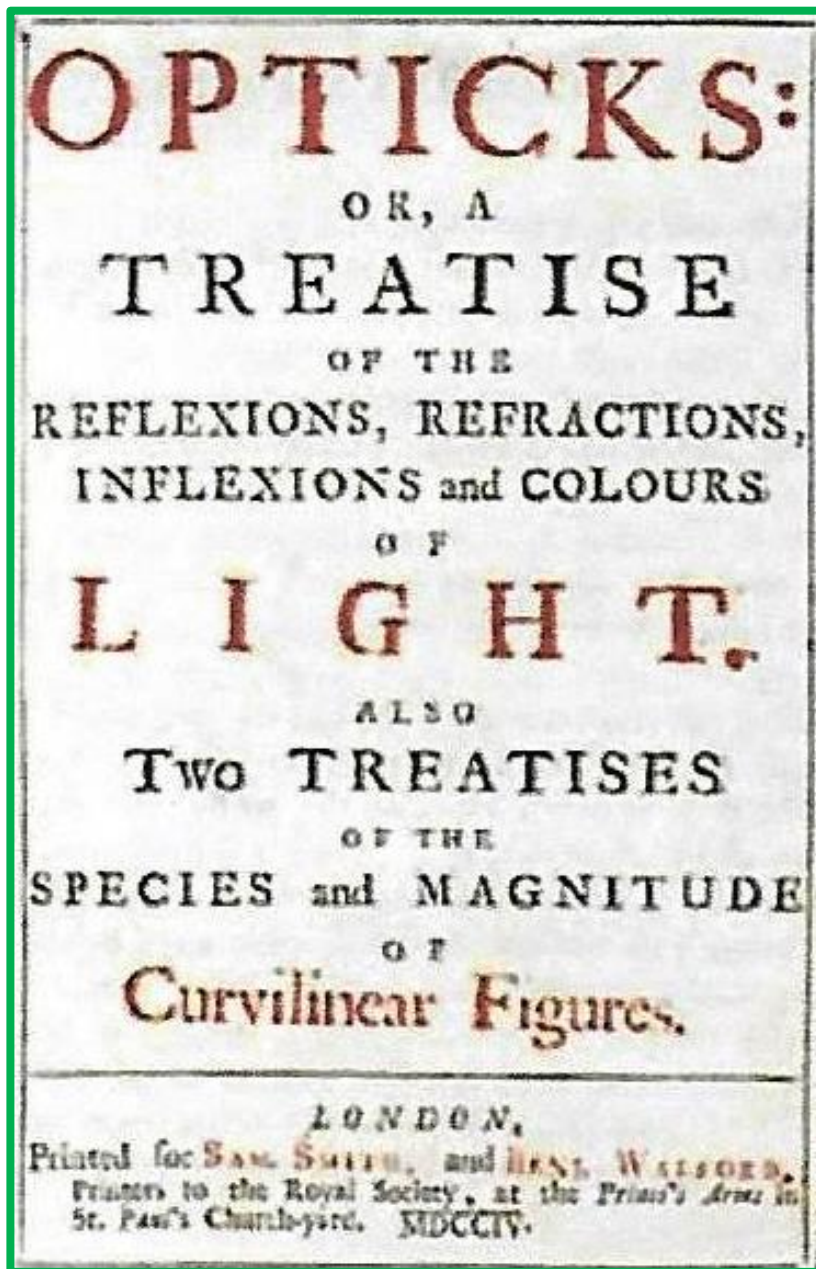

# Disputes and disagreements



**John Flamsteed**



**Gottfried Leibniz**

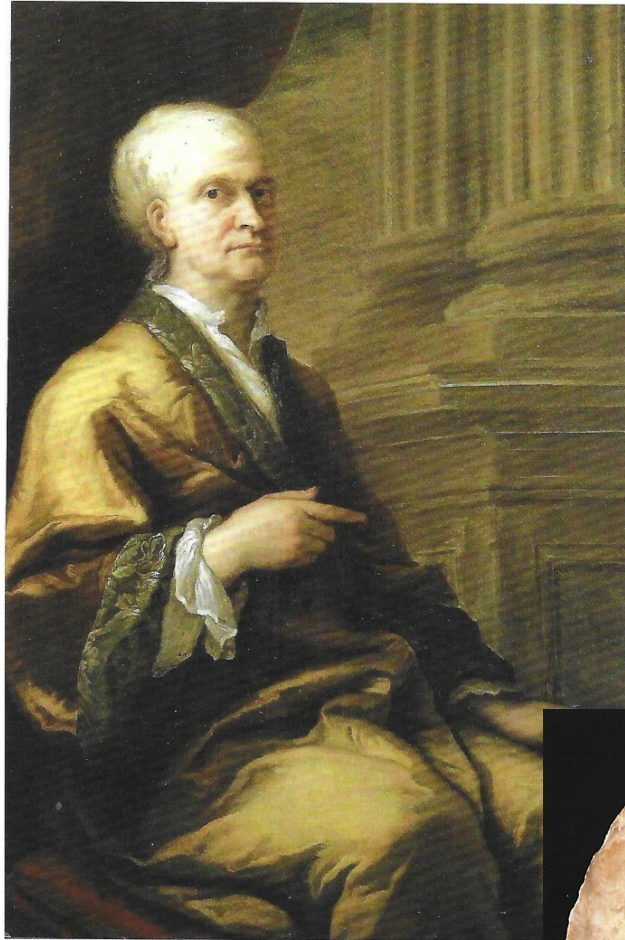

**Final  
years**



**Westminster Abbey**

# Reception of the *Principia*



**John Aubrey:**

‘... the greatest Discovery in Nature that ever was since the World’s Creation. It never was so much as hinted by any man before’.



**Guillaume de l’Hôpital:**

‘Good God, what a fund of knowledge there is in that book’ – and asking all sorts of questions about Sir Isaac, such as the colour of his hair, and ‘does he eat & drink & sleep?’ and ‘Is he like other men?’

# Translations & commentaries

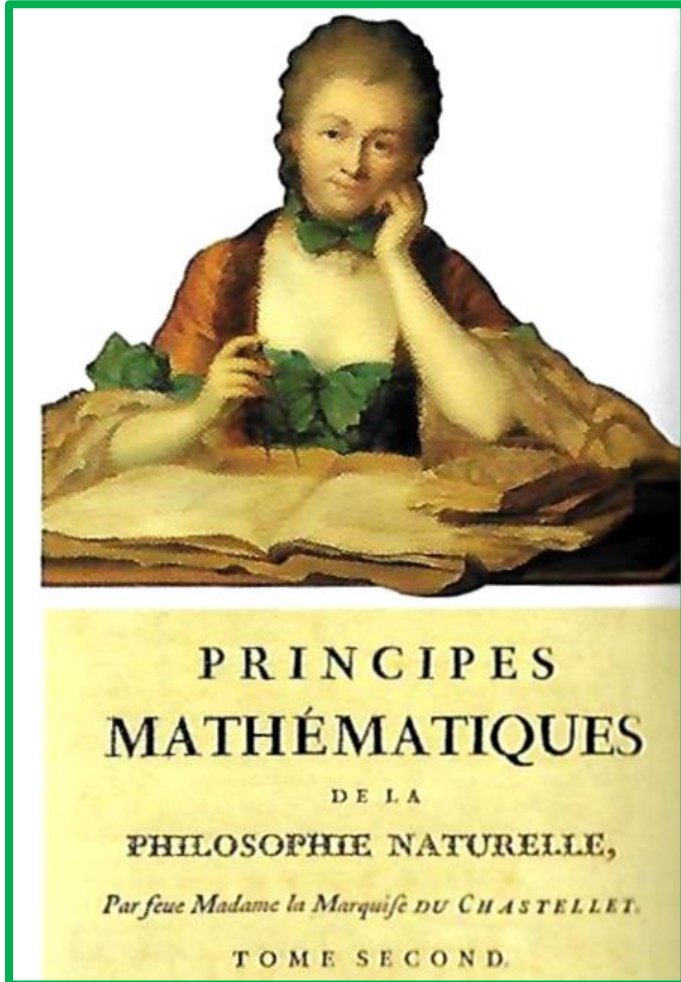

Emilie du Châtelet

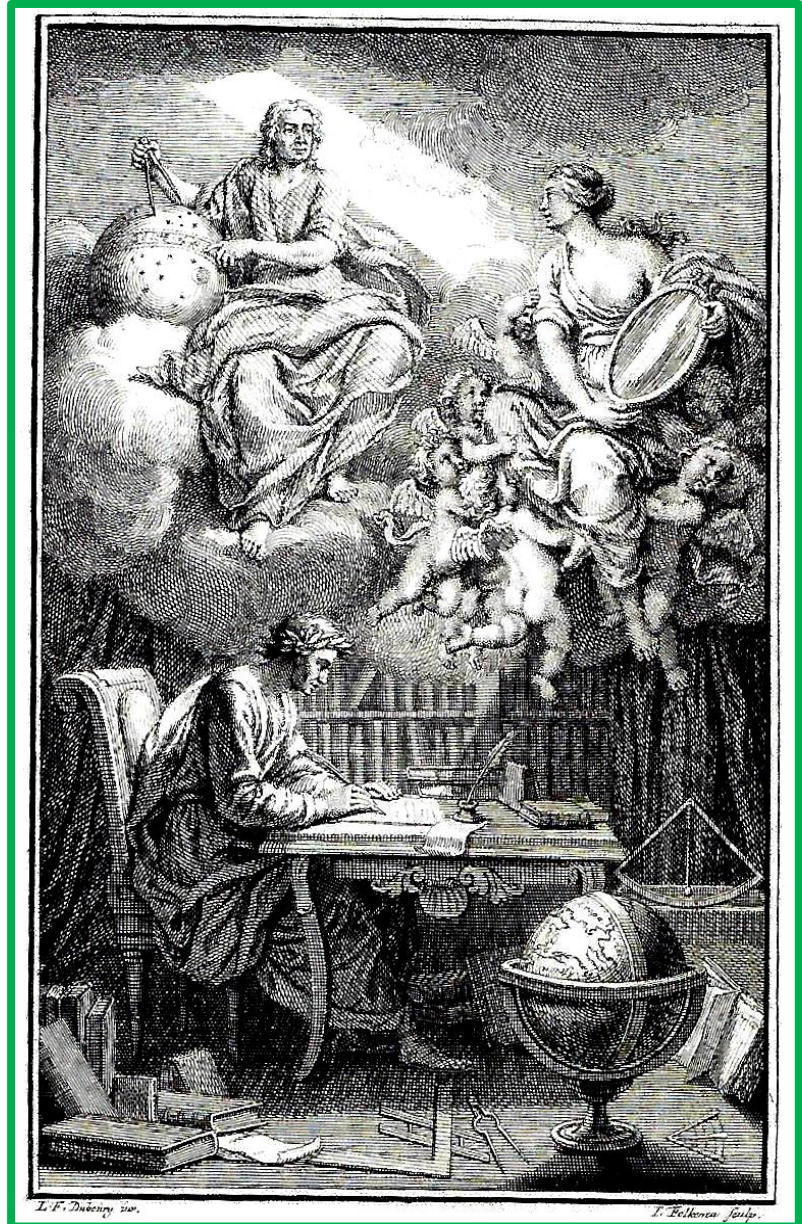

Voltaire

# *Newtonianism for the Ladies*

Francesco Algarotti



IL NEWTONIANISMO  
PER LE DAME,  
OVVERO  
DIALOGHI  
SOPRA  
LA LUCE E I COLORI.

---

*quæ legat ipsa Lycoris.*

Virg. Egl. X.

---



---

IN NAPOLI

---

MDCCXXXVII

# Newton for the young

## Tom Telescope





# Blake and Paolozzi

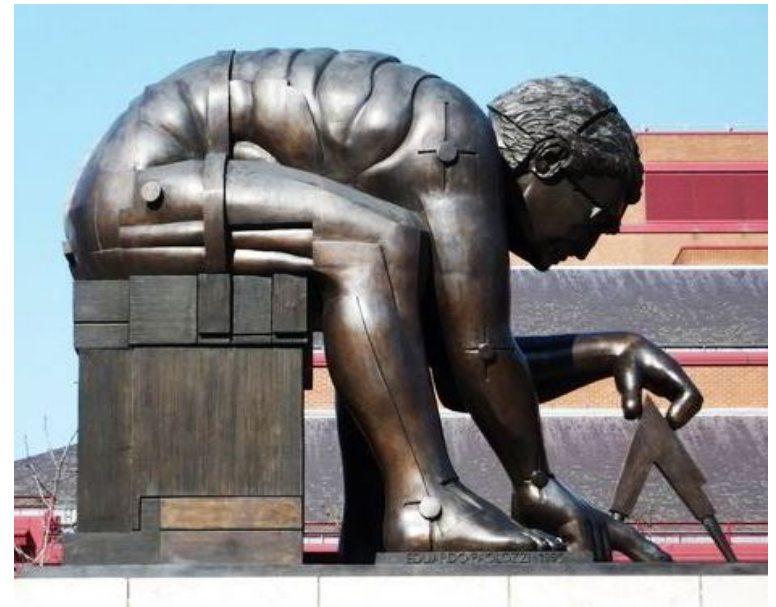
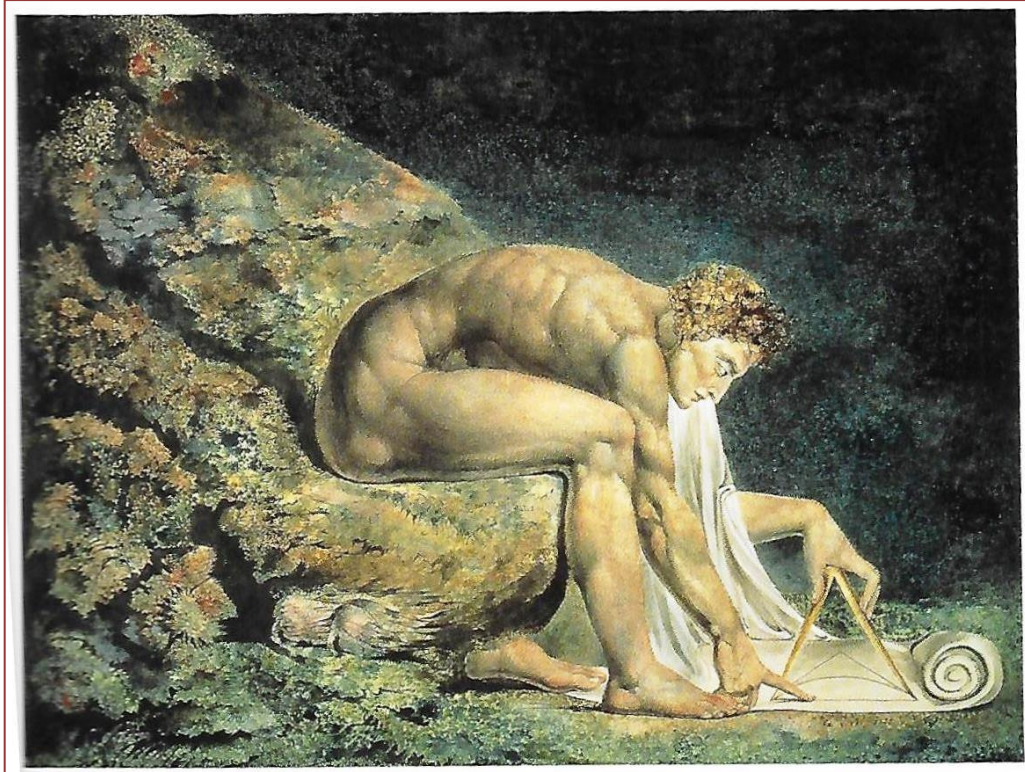

# Salvador Dali's *Homage to Newton*

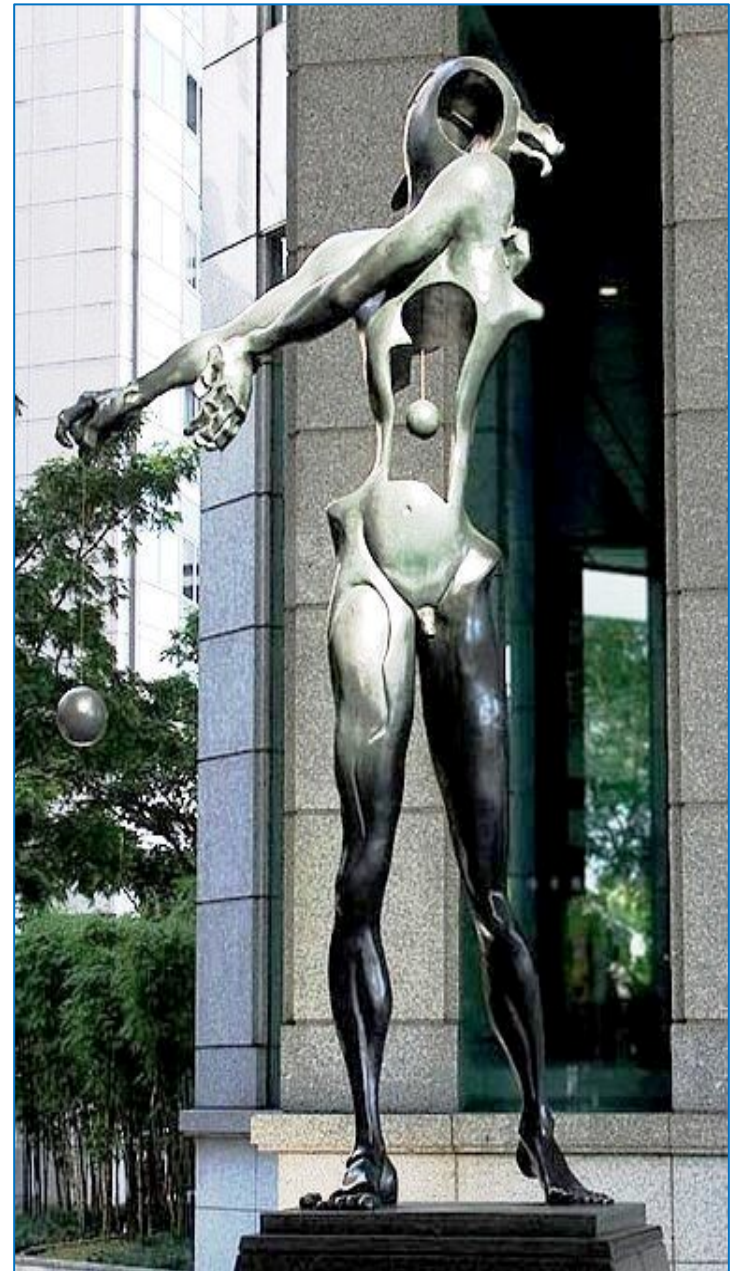
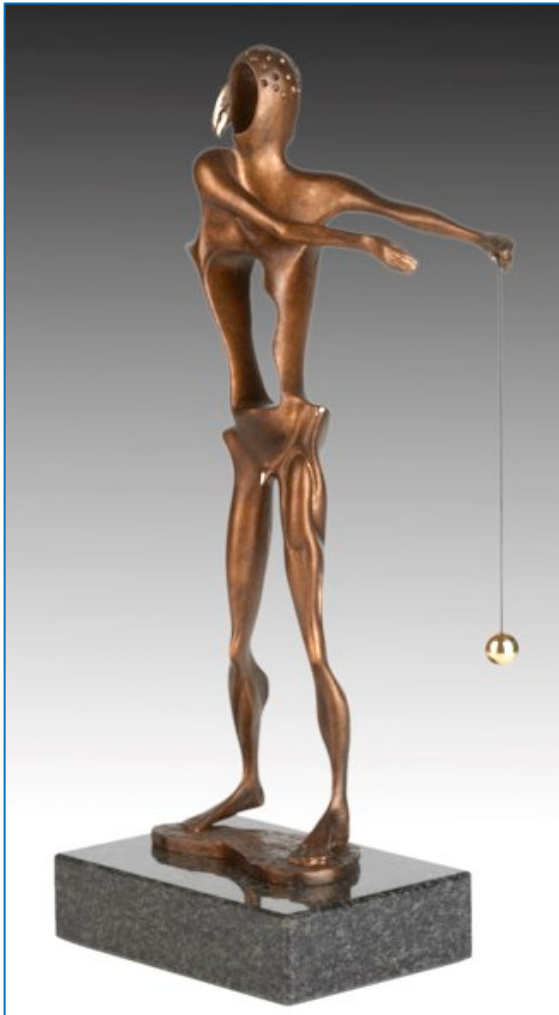

# Money & medals

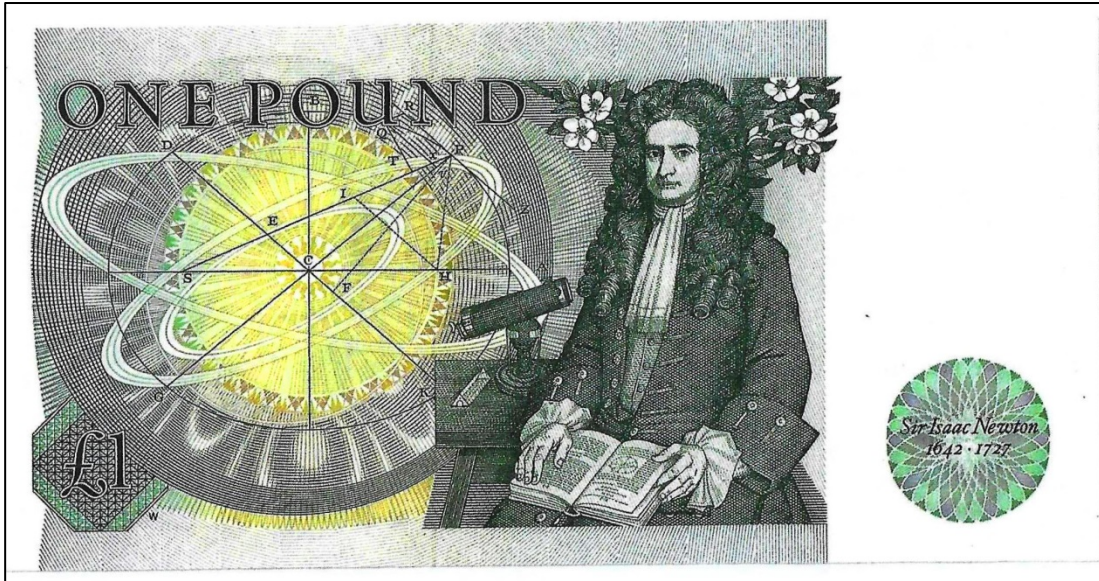

**British  
postage  
stamps  
1987**



# Some world-wide postage stamps

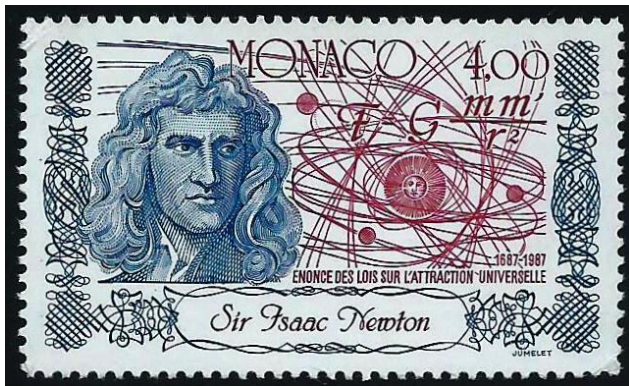
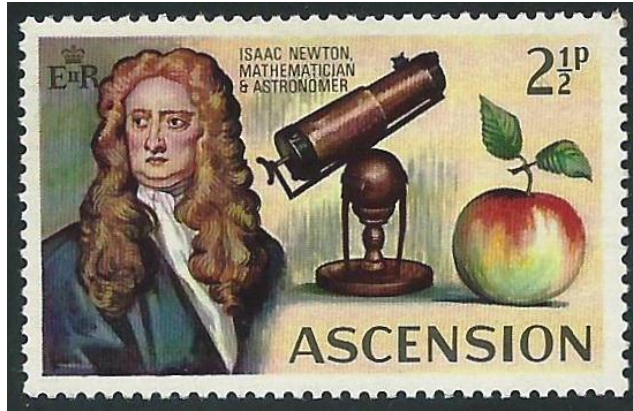

# Two quotations



I do not know what I may appear to the world, but to myself I seem to have been only like a boy playing on the sea-shore, and diverting myself in now and then finding a smoother pebble or a prettier shell than ordinary, whilst the great ocean of truth lay all discovered before me.

**Isaac Newton**

**Nature and Nature's Laws  
lay hid in Night.  
God said, *Let Newton be!*  
and All was *Light*.**

**Alexander Pope**



# Halley's *Ode to Isaac Newton*

Then ye who now upon heavenly nectar fare,  
Come celebrate with me in song the name  
Of Newton, to the Muses dear; for he  
Unlocked the hidden treasures of Truth:  
So richly through his mind had Phoebus cast  
The radiance of his own divinity.  
Nearer the gods no mortal may approach.

**Edmond Halley**

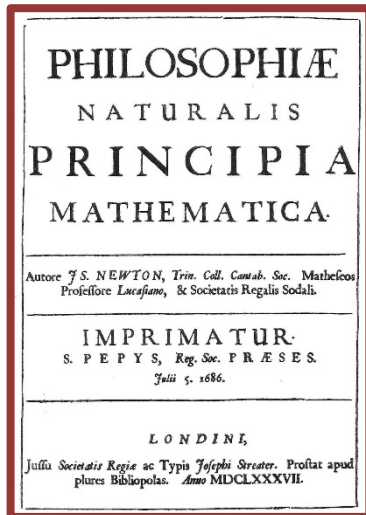

# Further reading

